

Watson-Marlow 720US NEMA 4X SCADA pumps



Contents

1	Declaration of conformity	3	16.3	Display	33
2	Declaration of incorporation	3	16.4	Outputs	34
3	Five-year warranty	3	16.5	Remote stop	36
4	When you unpack your pump	4	16.6	Auto-restart	37
5	Information for returning pumps	5	16.7	Set maximum allowed speed	38
6	Peristaltic pumps: an overview	5	16.8	Set minimum allowed speed	38
7	Safety notes	6	16.9	Scrolling	39
8	Pump specifications	8	16.10	Date and time	39
8.1	Dimensions	13	16.11	Backlight	40
9	Good pump installation practice	14	16.12	ROM	40
9.1	General recommendations	14	16.13	Language	41
9.2	Do's and do not's	15	16.14	Defaults	41
10	Connecting this product to a power supply	16	16.15	Security code	42
11	Start-up check list	17	16.16	Exit	43
12	Switching the pump on for the first time	17	17	MemoDose and calibration	43
13	Switching the pump on in subsequent power cycles (if not in auto-restart mode)	19	17.1	Changing dosing speed	44
14	Manual operation	20	17.2	Footswitch operation and other remote inputs and outputs with MemoDose	45
14.1	Keypad functions	20	17.3	Flow calibration	45
14.2	Speed	23	17.4	Exit	47
14.3	Direction	23	18	Exit	47
14.4	Keypad lock	24	19	Automatic control wiring using the 720N module	48
14.5	Keypad beep	24	19.1	720N module removal and replacement	48
14.6	To reset defaults	25	19.2	Wiring up	49
14.7	To reset language	25	19.3	Speed: analogue input	52
14.8	Backlight	25	19.4	Speed: analogue output	52
14.9	Auto-restart	25	19.5	Run/stop input	53
14.10	Manual operation and remote digital inputs and outputs	26	19.6	Direction input	53
15	Main menu	27	19.7	Auto / manual toggle input	54
15.1	Keypad functions in menu screens	27	19.8	MemoDose input	54
15.2	Main menu entry	27	19.9	Leak detection input	55
16	Setup	29	19.10	Outputs 1, 2, 3, 4	56
16.1	Trim	30	20	Automatic control and operation	57
16.2	Analogue	31	21	Troubleshooting	58
16.2.1	Input speed	32	21.1	Error codes	59
16.2.2	Trim	33	22	Drive maintenance	60
16.2.3	Menu	33	23	Drive spares	60

24	720R, 720RX, 720RE and 720REX pumpheads installation	60	element models 720RE and 720REX	68
24.1	Pumphead do's and do not's	60	29 Pumphead spares: rotor	69
24.2	720R, 720RX, 720RE and 720REX		30 720R and 720RE flow rates	70
	Key safety information	61	31 720RE LoadSure element product codes	70
24.3	720R, 720RX, 720RE and 720REX		32 720R continuous tubing product codes	71
	safe-guarding	61	33 Trademarks	71
24.4	All 720R and 720RE pumping conditions	61	34 Warning not to use pumps in patient-connected applications	71
24.5	All 720R and 720RE pumpheads: fluid management	61	35 Publication history	71
25	Pumphead fitting	62	36 Decontamination certificate	72
25.1	Removing and refitting the pumphead	62		
25.2	Removing and refitting an extension pumphead	63		
26	Tube loading	64		
26.1	720R and 720RX continuous tube loading	64		
26.2	720RE and 720REX LoadSure element loading	66		
27	Pumphead spares: continuous tubing models 720R and 720RX	67		
28	Pumphead spares: LoadSure			

1 Declaration of conformity



This declaration was issued for Watson-Marlow 720US pumps on July 1, 2007. When this pump unit is used as a stand-alone pump it complies with: Machinery Directive 2006/42/EC, EMC Directive 2004/108/EC.



This pump is ETL listed: ETL control number 3050250. Cert to CAN/CSA std C22.2 No 61010-1. Conforms to UL std 61010A-1.

See 8 Pump specifications.

2 Declaration of incorporation

When this pump unit is to be installed into a machine or is to be assembled with other machines for installations, it must not be put into service until the relevant machinery has been declared in conformity with the Machinery Directive 2006/42/EC.

Responsible person: Christopher Gadsden, Managing Director, Watson-Marlow Limited, Falmouth, Cornwall TR11 4RU, England. Telephone +44 (0) 1326 370370 Fax +44 (0) 1326 376009.

The information in this user guide is believed to be correct at the time of publication. However, Watson-Marlow Limited accepts no liability for errors or omissions. Watson-Marlow Bredel has a policy of continuous product improvement, and reserves the right to alter specifications without notice. This manual is intended for use only with the pump it was issued with. Earlier or later models may differ. The most up-to-date manuals appear on the Watson-Marlow website: <http://www.watson-marlow.com>

3 Five-year warranty

520 cased pumps, 620 cased pumps and 720 cased pumps

For any 520, 620 or 720 cased pump purchased after 1 January 2007, Watson-Marlow Limited ("Watson-Marlow") warrants, subject to the conditions and exceptions below, through either Watson-Marlow, its subsidiaries, or its authorised distributors, to repair or replace free of charge, any part of the product which fails within five years of the day of manufacture of the product. Such failure must have occurred because of defect in material or workmanship and not as a result of operation of the product other than in normal operation as defined in this pump manual.

Watson-Marlow shall not be liable for any loss, damage, or expense directly or indirectly related to or arising out of the use of its products, including damage or injury caused to other products, machinery, buildings, or property, and Watson-Marlow shall not be liable for consequential damages, including, without limitation, lost profits, loss of time, inconvenience, loss of product being pumped, and loss of production. This warranty does not obligate Watson-Marlow to bear any costs of removal, installation, transportation, or other charges which may arise in connection with a warranty claim.

Conditions of and specific exceptions to the above warranty are:

Conditions

- Products must be returned by pre-arrangement, carriage-paid, to Watson-Marlow, or a Watson-Marlow approved service centre.
- All repairs or modifications must have been made by Watson-Marlow Limited, or a Watson-Marlow approved service centre or with the express permission of Watson-Marlow.
- Warranties purporting to be on behalf of Watson-Marlow made by any person, including representatives of Watson-Marlow, its subsidiaries, or its distributors, which do not accord with the terms of this warranty shall not be binding upon Watson-Marlow unless expressly approved in writing by a Director or Manager of Watson-Marlow.

Exceptions

- The warranty shall not apply to repairs or service necessitated by normal wear and tear or for lack of reasonable and proper maintenance.
- All tubing and pumping elements as consumable items are excluded.
- Products which, in the judgment of Watson-Marlow, have been abused, mis-used, or subjected to malicious or accidental damage or neglect are excluded.
- Electrical surge as a cause of failure is excluded.
- Chemical attack is excluded
- All pumphead rollers are excluded.
- 620R pumpheads are consumable and excluded from all warranty when pumping above 2 bar while above 165rpm.
- Pumpheads from the 313/314 and the Microcassette ranges and any 701/720 extension pumpheads are excluded and retain their one-year standard pump-head warranty. The drive they are attached to is subject to the five-year warranty as set out here.
- Ancillaries such as leak detectors are excluded.

4 When you unpack your pump

Note on lifting: The pump weighs more than 18kg (the exact weight depends on model and pumphead—see 8 Pump specifications). Lifting should be performed according to standard Health and Safety guidelines.

Unpack all parts carefully, retaining the packaging until you are sure all components are present and in good order. Check against the components supplied list, below.

Packaging disposal

Dispose of packaging materials safely, and in accordance with regulations in your area. The outer carton is made of corrugated cardboard and can be recycled.

Inspection

Check that all components are present. Inspect components for damage in transit. If anything is missing or damaged, contact your distributor immediately.

Components supplied

720US pumps are supplied as:

- Dedicated 720 pump drive unit fitted with 720R, 720RE, 720RX or 720REX pumpheads (see 8. Pump specifications).

- A 720N SCADA module providing pump ingress protection to IP66, NEMA 4X.
Note: the module is attached for transit, but must be removed to allow wiring up, voltage selection and fuse inspection and then re-affixed before the pump is operated.
- The designated mains power lead for your pump
- PC-readable CDROM containing these operating instructions
- Quick Start manual

Note: Some versions of this product will include components different from those listed above. Check against your purchase order.

Storage

This product has an extended shelf life. However, care should be taken after storage to ensure that all parts function correctly. Users should be aware that the pump contains a battery with an unused life of seven years. Long-term storage is not recommended for peristaltic pump tubing. Please observe the storage recommendations and use-by dates which apply to tubing you may wish to bring into service after storage.

5 Information for returning pumps

Equipment which has been contaminated with, or exposed to, body fluids, toxic chemicals or any other substance hazardous to health must be decontaminated before it is returned to Watson-Marlow or its distributor.

A certificate included at the rear of these operating instructions, or signed statement, must be attached to the outside of the shipping carton. This certificate is required even if the pump is unused.

If the pump has been used, the fluids that have been in contact with the pump and the cleaning procedure must be specified along with a statement that the equipment has been decontaminated.

6 Peristaltic pumps - an overview

Peristaltic pumps are the simplest pump, with no valves, seals or glands to clog or corrode. The fluid contacts only the bore of a tube, eliminating the risk of the pump contaminating the fluid, or the fluid contaminating the pump. Peristaltic pumps can run dry.

How they work

A compressible tube is squeezed between a roller and a track on an arc of a circle, creating a seal at the point of contact. As the roller advances along the tube, the seal also advances. After the roller has passed, the tube returns to its original shape, creating a partial vacuum which is filled by fluid drawn from the inlet port.

Before the roller reaches the end of the track, a second roller compresses the tube at the start of the track, isolating a packet of fluid between the compression points. As the first roller leaves the track, the second continues to advance, expelling the packet of fluid through the pump's discharge port. At the same time, a new partial vacuum is created behind the second roller into which more fluid is drawn from the inlet port.

Backflow and siphoning do not occur, and the pump effectively seals the tube when it is inactive. No valves are needed.

The principle may be demonstrated by squeezing a soft tube between thumb and finger and sliding it along: fluid is expelled from one end of the tube while more is drawn in at the other.

Animal digestive tracts function in a similar way.

Suitable applications

Peristaltic pumping is ideal for most fluids, including viscous, shear-sensitive, corrosive and abrasive fluids, and those containing suspended solids. They are especially useful for pumping operations where hygiene is important.

Peristaltic pumps operate on the positive displacement principle. They are particularly suitable for metering, dosing and dispensing applications. Pumps are easy to install, simple to operate and inexpensive to maintain.

7 Safety notes

In the interests of safety, this pump and the tubing selected should only be used by competent, suitably trained personnel after they have read and understood this manual, and considered any hazard involved. If the pump is used in a manner not specified by Watson-Marlow Limited, the protection provided by the pump may be impaired.



This symbol, used on the pump and in this manual, means: Caution, risk of electric shock.



This symbol, used on the pump and in this manual, means: Caution, refer to accompanying documents.



This symbol, used on the pump and in this manual, means: Do not allow fingers to contact moving parts.



This symbol, used on the pump and in this manual, means: Recycle this product under the terms of the EU Waste Electrical and Electronic Equipment (WEEE) Directive.



There is a user-replaceable type T5A H 250V fuse in the fuseholder in the centre of the switchplate at the back of the pump.

The 720N SCADA module must be removed to allow access to the switchplate. See 19.1 720N SCADA module removal and replacement. There are thermal fuses within the pump which self-reset within 60 seconds; if they trip an error code is displayed.



Fundamental work with regard to lifting, transportation, installation, starting-up, maintenance and repair should be performed by qualified personnel only. The unit must be isolated from mains power while work is being carried out.

Any person who is involved in the installation or periodic maintenance of this equipment should be suitably skilled or instructed and supervised using a safe system of work. In the UK this person should also be familiar with the Health and Safety at Work Act 1974.

There are moving parts inside the pumphead. Before opening the tool-unlockable track, ensure that the following safety directions are followed.

- Ensure that the pump is isolated from the mains power.
- Ensure that there is no pressure in the pipeline.
- If a tube failure has occurred, ensure that any fluid in the pumphead has been allowed to drain to a suitable vessel, container or drain.
- Ensure that protective clothing and eye protection are worn if hazardous fluids are pumped.
- Primary operator protection from rotating parts of the pump is provided by the pumphead track. See the pumphead section of this manual: 24.
- Secondary operator protection from rotating parts of the pump is provided by indicator-only switching of the pumphead track. This function will stop the pump if the track is inadvertently opened while the pump is running.



This product does not comply with the ATEX directive and must not be used in explosive atmospheres.

This pump must be used only for its intended purpose. The pump must be accessible at all times to facilitate operation and maintenance. Access points must not be obstructed or blocked. The pump's mains plug is the disconnecting device (for isolating the motor drive from the mains supply in an emergency). Do not position the pump so that it is difficult to disconnect the mains plug. Do not fit any devices to the drive unit other than those tested and approved by Watson-Marlow. Doing so could lead to injury to persons or damage to property for which no liability can be accepted.

If hazardous fluids are to be pumped, safety procedures specific to the particular fluid and application must be put in place to protect against injury to persons.

The exterior surfaces of the pump may get hot during operation. Do not take hold of the pump while it is running. Let it cool after use before handling it.

No attempt should be made to run the drive without a pumphead fitted.

Lifting

The unit weighs more than 18kg (the exact weight depends on model and pumphead—see 8 Pump specifications). Lifting should be performed according to standard Health and Safety guidelines.

8 Pump specifications

Labels fixed to the rear of the pump contain manufacturer and contact details, product reference number, serial number and model details.



The same information is carried on the drive's backplate, accessible when the 720N SCADA module is removed. The number of connectors varies according to the model.

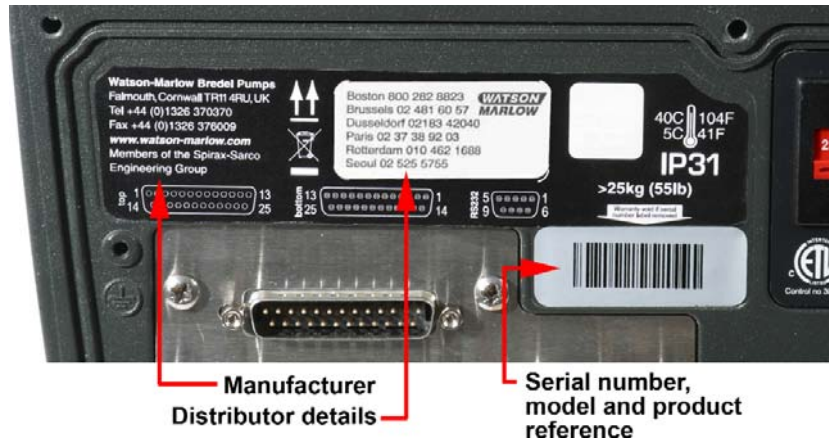

720US, IP66 NEMA 4X model

This pump can be controlled from the keypad or remotely. It features:

Manual control

Speed adjustment; run and stop; direction control; keypad scaling; "max" key for rapid priming.

Remote control

The pump can be digitally controlled with a contact closure or logic input signal.

Analogue control

The pump speed can be controlled through an analogue signal input in the ranges 0-10V, 1-5V or 4-20mA.

Outputs

A 0-10V or 0-768Hz output signal provides feedback of the pump speed. There are four relay status outputs which can be configured in software for a variety of pump parameters.

MemoDose

Allows repeat dosing. Stores in memory a pulse count from the motor. This count is repeated each time **START** is pressed to provide a single-shot dose.

Calibration

Uses the same pulse count as MemoDose. The corresponding pumped volume can be entered to calibrate the flow of the pump.

Guard switch

Primary operator protection from rotating parts of the pump is provided by the pumphead track. Secondary operator protection from rotating parts of the pump is provided by indicator-only switching of the pumphead track.

IP (Ingress Protection) and NEMA definitions

IP		NEMA
1st Digit	2nd Digit	
3 Protected against ingress of solid objects with a diameter of more than 2.5mm. Tools, wires etc with a thickness of more than 2.5mm are prevented from approach	1 Protection against dripping water falling vertically. No harmful effect must be produced	2 Indoor use to provide a degree of protection against limited amounts of falling water and dirt
5 Protected against harmful dust deposits. Ingress of dust is not totally prevented but the dust must not enter in sufficient quantity to interfere with satisfactory operation of the equipment. Complete protection against contact	5 Protection against water projected from a nozzle against the equipment (enclosure) from any direction. There must be no harmful effect (water jet)	12 Indoor use to provide a degree of protection against dust, falling dirt and dripping, non-corrosive liquids
		13 Indoor use to provide a degree of protection against dust and spraying of water, oil and non-corrosive coolants
6 Protection against ingress of dust (dust-tight). Complete protection against contact	6 Protection against heavy seas or powerful water jets. Water must not enter the equipment (enclosure) in harmful quantities (splashing over)	4X Indoor or outdoor use* to provide a degree of protection against splashing water, wind-blown dust and rain, hose-directed water; undamaged by the formation of ice on the enclosure. (Resist corrosion: 200-hour salt spray)

* 720N SCADA cased pumps are rated to NEMA 4X (indoor use) only.

Unit weights

	Drive only	+ 720R, 720RE	+ 720RX, 720REX
IP66 NEMA 4X	18.5kg, 40lb 13oz	25kg, 55lb 2oz	31.5kg, 69lb 7oz

Pump specifications

Control range (turndown ratio)	0.1-360rpm (3,600:1)
Supply voltage/frequency	Filtered 100-120V/200-240V 50/60Hz 1ph
Maximum voltage fluctuation	±10% of nominal voltage. A well regulated electrical mains supply is required along with cable connections conforming to the best practice of noise immunity
Installation category (overvoltage category)	II
Power consumption	350VA
Full load current	<1.5A at 230V; <3.0A at 115V
Eprom version	Accessible through pump software
Enclosure rating	IP66 to BS EN 60529; Equivalent to NEMA 4X to NEMA 250* (indoor use). Suitable for heavy industrial, process and dirty environments. The drive uses a Gore membrane vent to equalise the pressure inside the enclosure and to prevent ingress of water and corrosive
Pumphead options	720R, 720RE, 720RX, 720REX
Operating temperature range	5C to 40C, 41F to 104F
Storage temperature range	-40C to 70C, -40F to 158F
Maximum altitude	2,000m, 6,560ft
Humidity (condensing)	10% - 100% RH
Weight	See table on previous page
Noise	<85dB(A) at 1m
Max peak pressure rating †	2 bar (30 psi)

* Protect from prolonged UV exposure.

† For all tube materials including STA-PURE.

Standards

EC harmonised standards	Safety of machinery—electrical equipment of machines: BS EN 60204-1	
	Safety requirements for electrical equipment for measurement, control and laboratory use: BS EN 61010-1 incorporating A2 Category 2, Pollution degree 2	
	Degrees of protection provided by enclosures (IP code): BS EN 60529 amendments 1 and 2	
	Conducted emissions: BS EN 55011 A1 and A2, Class A, called by BS EN 61000-6-4	
	Radiated emissions: BS EN 55011 A1 and A2, Class A, called by BS EN 61000-6-4	
	Electrostatic discharge: BS EN 61000-4-2	
	Radiated RF immunity: BS EN 61000-4-3 A1 and A2, called by BS EN 61000-6-2	
	Fast transient burst: BS EN 61000-4-4 A1 and A2, Level 3 (2kV), called by BS EN 61000-6-2	
	Surge immunity: BS EN 61000-4-5 A1 and A2, called by BS EN 61000-6-2	
	Conducted RF immunity: BS EN 61000-4-6, called by BS EN 61000-6-2	
	Voltage dips and interruptions: BS EN 61000-4-11, called by BS EN 61000-6-2	
	Mains harmonics: BS EN 61000-3-2 A2	
	Pumps and pump units for liquids—common safety requirements: BS EN 809	
	Other standards	UL 61010A-1
		CAN/CSA-C22.2 No 61010-1
Conducted emissions FCC 47CFR, Part 15.107		
Radiated emissions FCC 47CFR, Part 15		
NEMA 4X to NEMA 250 (indoor use) for IP66 products only		

8.1 Dimensions

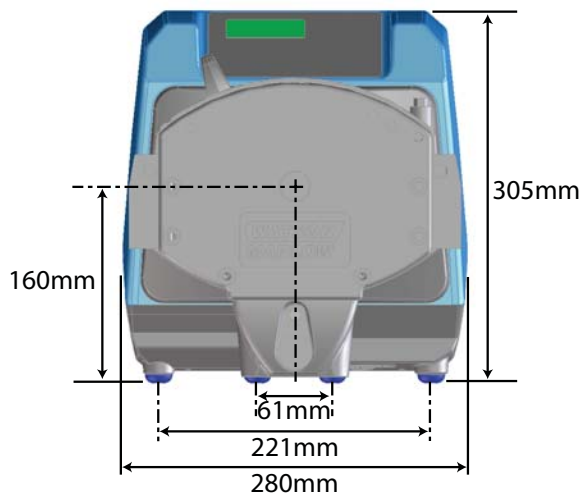
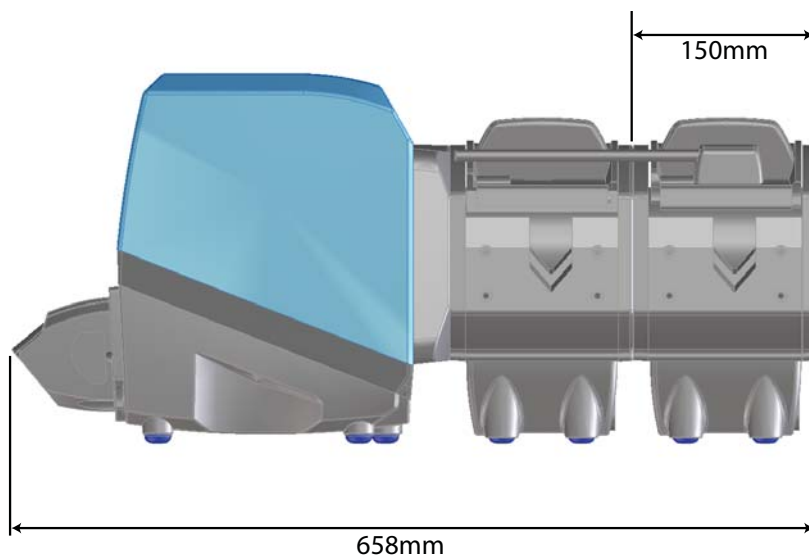
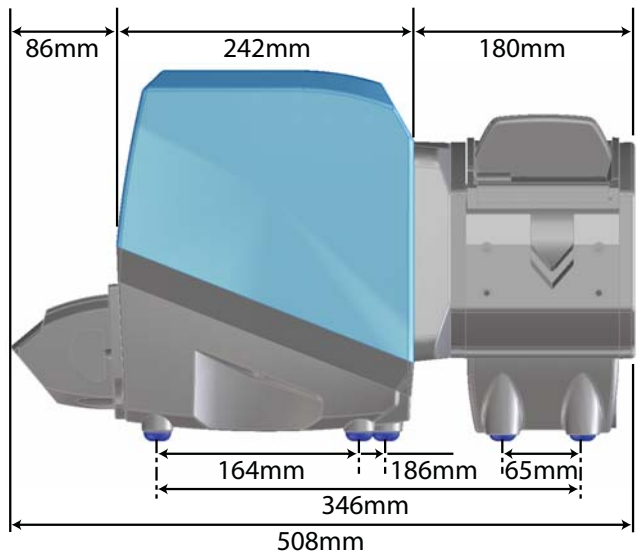

9 Good pump installation practice

9.1 General recommendations

Position

A correctly engineered installation will promote long tube life. Site the pump on a flat, horizontal, rigid surface, free from excessive vibration. Allow a flow of air around the pump to ensure that heat can be dissipated. Ensure that the temperature around the pump does not exceed 40C.

Do not stack other 720 pumps on top of this pump. It is, however, acceptable to stack other equipment on the upper surface of the 720 (as long as the ambient temperature does not exceed 40C).

Emergency disconnection

The pump's mains plug is the disconnecting device (for isolating the motor drive from the mains supply in an emergency). Do not position the pump so that it is difficult to disconnect the mains plug. The **STOP** key on the keypad will always stop the pump. However, it is recommended that a suitable local emergency stop device is fitted into the mains supply to the pump.

Valves

Peristaltic pumps are self-priming and self-sealing against backflow. No valves are required in inlet or discharge lines. Valves in the process flow must be opened before the pump operates. Users are advised to fit a pressure relief device between the pump and any valve on the discharge side of the pump to protect against damage caused by accidental operation with the discharge valve closed.

The pump may be set up so that the direction of rotor rotation is clockwise or counter-clockwise, whichever is convenient.

Tubing materials: run-in advice

Sta-Pure and Marprene tubing are hard to compress when new. When using tubing made of these materials, the first 30 seconds should be at a speed of 10 rpm or greater. If the pump is run slower, the safety system built into pump drive's software may cause it to stop and display an over-current error message.

Connecting pipework

When using elements in a 720RE or 720REX pumphead, ensure that at least 600mm (2ft) of the connecting pipework rises as it approaches the pumphead on both the inlet and discharge sides. This helps the sliders which hold the element in place to find their optimum position. Failure to do this may result in premature element failure.

9.2 Do's and do not's

Do not build a pump into a tight location without adequate airflow around the pump.

Do ensure that when the 720N SCADA watertight module is fitted the seals are intact and properly located. Ensure that the holes for cable glands are properly sealed to maintain the IP66 / NEMA 4X rating.

Do not strap the control and mains power cables together.

Do keep delivery and suction tubes as short and direct as possible - though ideally not shorter than 1m - and follow the straightest route. Use bends of large radius: at least four times the tubing diameter. Ensure that connecting pipework and fittings are suitably rated to handle the predicted pipeline pressure. Avoid pipe reducers and lengths of smaller bore tubing than the pumphead section, particularly in pipelines on the suction side. When pumping viscous fluids use pipe runs with a bore several times larger than the pump tube. Any valves in the pipeline (not usually needed) must not restrict the flow. Any valves in the flow line must be open when the pump is running.

Do ensure that on longer tube runs at least 1m of smooth bore flexible tubing is connected to the inlet and discharge port of the pumphead to help to minimize impulse losses and pulsation in the pipeline. This is especially important with viscous fluids and when connecting to rigid pipework.

Do site the pump at or just below the level of the fluid to be pumped if possible. This will ensure flooded suction.

Do keep the pumphead track and all moving parts clean and free from contamination and debris.

Do run at slow speed when pumping viscous fluids. Flooded suction will enhance pumping performance in all cases, particularly for materials of a viscous nature.

Do recalibrate after changing pump tubes, fluid, or any connecting pipework. It is also recommended that the pump is recalibrated periodically to maintain accuracy.

IP66 / NEMA 4X models may be hosed down, but should not be immersed. Protect from prolonged UV exposure.

When using Marprene or Bioprene continuous tubing, do re-tension the tube after the first 30 minutes of running.

Tube selection: The chemical compatibility lists published in Watson-Marlow publications are guides. If in doubt about the compatibility of a tube material and the duty fluid, request a Watson-Marlow tube sample card for immersion trials.

Do not run the pump with no tube or element fitted to the pumphead. If the direction is changed, the rotor will continue turning as it tries to reverse and the software will flag an error condition.

10 Connecting this product to a power supply

A well regulated electrical mains supply is required along with cable connections conforming to the best practice of noise immunity. It is not recommended to site these drives alongside “dirty” electrical mains supplies such as 3-phase contactors and inductive heaters without special attention being paid to unacceptable mains-borne noise.



The voltage selector is mounted in the switchplate at the rear of the pump, protected from water by the 720N SCADA module. The module must be removed to allow access to the switchplate. See 19.1 720N SCADA module removal and replacement. Set the voltage selector to 115V for 100-120V 50/60Hz supplies or 230V for 200-240V 50/60Hz supplies. Always check the voltage selector switch before connecting the mains supply. Make suitable connection to an earthed, single-phase mains electricity supply. To comply with Safety Standards, the mains plug must be a separable plug (not a locking type).

 **We recommend using commercially available supply voltage surge suppression where there is excessive electrical noise.**

Power cable: The pump is supplied fitted with either of two cable glands and approximately 2.8m of power cable. The European cable is to Harmonised code H05RN-F3G0.75, used with our gland part number SL0128 which is suitable for an outside cable sheath diameter of 4-7mm. The north American cable is to type SJTOW 105C 3-18AWG VW-1 used with our gland part number SL0123 which is suitable for an outside cable sheath diameter of 7-9mm.

Power cables of NEMA 4X specification pumps are fitted with a standard US mains power plug. IP66 specification pumps are supplied with no plug. Wiring a mains plug must only be undertaken by suitably skilled, qualified personnel.

Conductor coding

	European	North American
line	brown	black
neutral	blue	white
ground	green/yellow	green

 **The voltage selector switch is not visible while the 720N SCADA module is in place. Do not switch the pump on unless you have checked that it is set to suit your power supply by removing the module and inspecting the switch, and then refitting the module. See 19.1 720N SCADA module removal and replacement.**

If the mains power cable is inappropriate for your installation, it can be changed. Please contact your local Watson-Marlow Bredel service centre.



Input line fusing: type T5A H 250V 20mm time-delayed cartridge fuse, located in a fuseholder in the centre of the switchplate at the rear of the pump.

Power interruption: This pump has an auto-restart feature which, when active, will restore the pump to the operating state it was in when power was lost. See 16.6 Auto-restart.

Stop / start power cycles: Do not power up/power down for more than 100 starts per hour, whether manually or by means of the auto-restart facility. We recommend remote control where a high number of starts is required.

11 Start-up check list

Note: See also 26, Tube loading.

- Ensure that proper connections are achieved between the pump tube and suction and discharge piping.
- Ensure proper connection has been made to a suitable power supply.
- Ensure that the recommendations in section 9 Good pump installation practice are followed.

12 Switching the pump on for the first time

Note: This manual uses **bold** type to highlight the active option in menu screens: “**English**” in the first screen represented here. The active option appears on the pump display in **inverse** text.

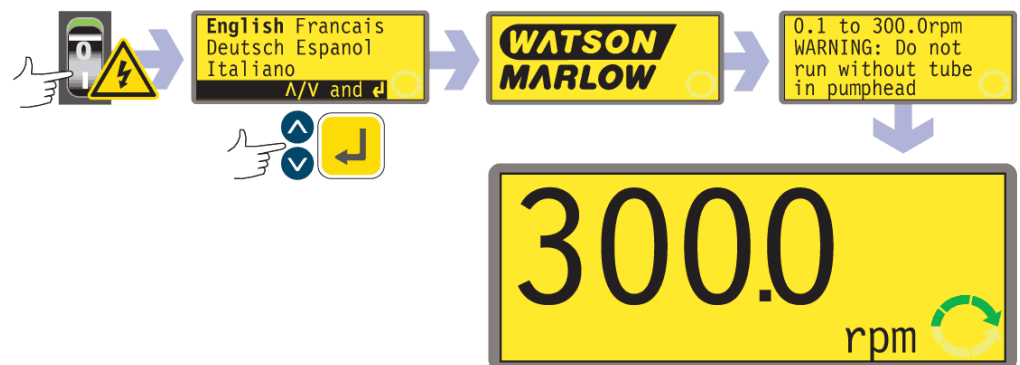

- Switch on the power supply at the rear of the pump. The pump runs a power-on test to confirm proper functioning of the memory and hardware. If a fault is found, an error message is displayed. See 21.1 Error codes.
- The pump displays a language menu. Use the **UP** and **DOWN** keys to select your language. Press the **ENTER** key to confirm your choice.
- **The information which follows assumes that your choice was English.**

- When the language is chosen this menu will not appear again and all menus will appear in the language you chose. (Language can be reset as described later. See 16.13 Language.)
- The pump displays the Watson-Marlow start-up screen for four seconds, followed by a warning screen for four seconds (an example is shown here), and then the manual mode main screen.
- The rotation symbol on the display indicates clockwise rotation. The default speed setting is 300 rpm, but 360 rpm is available (see 16.7 Set maximum allowed speed). Other initial start-up operational parameters are listed in the table below.

720US: First-time start-up defaults			
Language	Not set	Analogue input	4-20mA
Speed	300 rpm	User trim	None
Direction	Clockwise	Remote stop	Open=run
Pumphead	720R	Scrolling increment	0.1rpm
Tube size	25.4mm	Output 1	Run/Stop *
Calibration	720R 25.4mm tube	Output 2	Direction †
Backlight	On	Output 3	Auto/Man ‡
Keypad lock	Off	Output 4	General alarm
Auto-restart	Off		
Pump status	Stopped		
Beeper	On	* Run	= high
Manual screen	rpm	† Clockwise rotation	= high
Security code	Not set	‡ Auto	= high

Note: The settings shown above for Run, Clockwise rotation and Auto are those in force on initial start-up for the functions available on Output 1, Output 2 and Output 3 respectively. For example, a high signal on Output 2 indicates clockwise rotation. These can be changed later according to user requirements.

Note: High is equivalent to the common and normally open contacts of the relay on the module board being closed.

The pump is now ready to operate according to the defaults listed above.

All operating parameters may be changed by means of key-presses. See 14 Manual operation.

13 Switching the pump on in subsequent power cycles (if not in auto-restart mode)

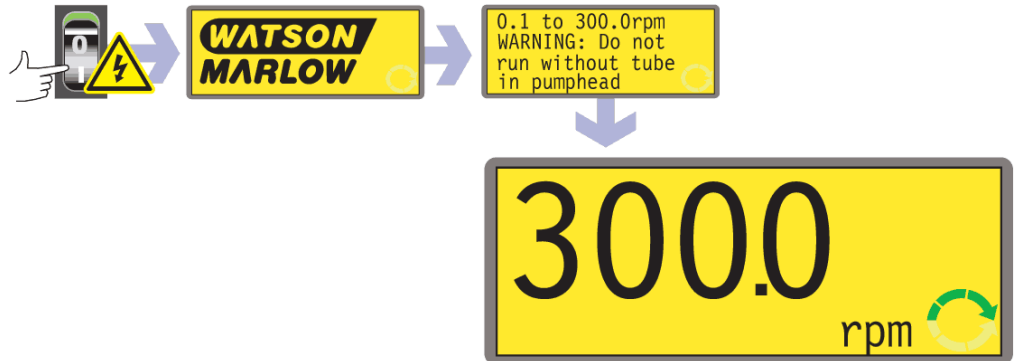

- Switch on the power supply at the rear of the pump. The pump runs a power-on test to confirm proper functioning of the memory and hardware. If a fault is found, an error message is displayed. See 21.1 Error codes.
- The pump displays the Watson-Marlow start-up screen for four seconds followed by a warning screen for four seconds (an example is shown here), and then the manual mode main screen.
- **Note:** Once in the manual mode main screen, keys assume their normal functions - see 15.1 Keypad in menu screens below. A subsequent press on **START** causes the pump to operate.
- Start-up defaults are those in place when the pump was switched off last. Check that the pump is set to operate as you require it.

The pump is now ready to operate.

All operating parameters may be changed by means of key-presses. See 14 Manual operation below.

14 Manual operation

14.1 Keypad functions

All settings and functions of the pump in manual mode are set and controlled by means of key-presses. Immediately after the start-up display sequence detailed above, the manual mode main screen will be displayed. The currently selected rotation direction is indicated on the display by a clockwise or counter-clockwise segmented arrow. If an exclamation mark (!) shows, it indicates that Auto-restart is on (see 14.10 Auto-restart). If a padlock icon (🔒) shows, it indicates that Keypad lock is on (see 14.5 Keypad lock).

Note: A number of the controls listed below are shortcuts to commands which are also available through the Main menu. See 15 Main menu.

A brief single press on each key triggers a beep sound (if enabled - see 14.6 Keypad beep) and causes the pump to function as follows:



- **START:** starts the pump at the speed and in the direction shown on the display. The rotation symbol will become animated to confirm that the pump is operating.

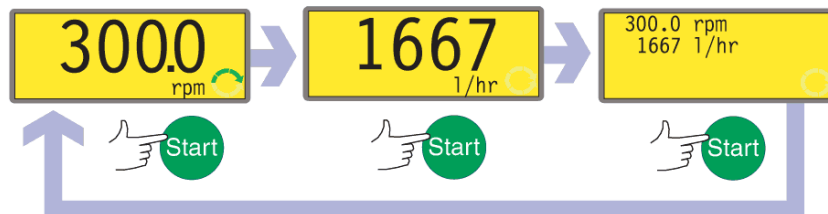

If the pump is running when **START** is pressed, it causes the information shown on the manual mode main screen to cycle from revolutions per minute, to flowrate in a choice of units (via a warning screen if flowrate has not been calibrated and if this is the first cycle since power-up) to rpm and flowrate. An example is shown here. The default can be altered from within the Setup menu (see 16.3 Display).

- **MAX:** while pressed, **MAX** operates the pump at the maximum allowed speed and in the direction shown on the display. When released, the pump returns to its previous status.
Note: Priming can be achieved by pressing the **MAX** key until fluid flows through the pump and reaches the point of discharge, and then releasing the **MAX** key.

- **AUTO/MAN**: toggles the pump into analogue control. When started, the pump runs at the speed set by any analogue signal applied to the pump, and in the direction shown in the display.
- **STOP**: if the pump is running, pressing **STOP** stops the pump. The display will continue to show the previous speed and direction. The pump will return to this speed and direction when the **START** key is pressed again.
- **UP**: increases the speed shown on the display in minimum steps of 0.1rpm, or other steps as pre-selected in the Scrolling section of the Setup menu, (unless the speed displayed is already the maximum allowed speed). If the pump is then started by pressing the **START** key, it will operate at the new speed. If the pump is running when **UP** is pressed, the change takes effect immediately.
Note: If the pump's flow rate has been calibrated (see 17.3 Calibration), after a speed change a screen showing the new rpm figure and the new flowrate is displayed for four seconds before returning the user to the previously set manual mode main screen: rpm or flowrate.
- **DOWN**: decreases the speed shown on the display in minimum steps of 0.1rpm, or other steps as pre-selected in the Scrolling section of the Setup menu. If the pump is then started by pressing the **START** key, it operates at the new speed. The minimum speed possible is 0.1rpm. If the pump is running when **DOWN** is pressed, the change takes effect immediately.
Note: If the pump's flow rate has been calibrated (see 17.3 Calibration), after a speed change a screen showing the new rpm figure and the new flowrate is displayed for four seconds before returning the user to the previously set manual mode main screen: rpm or flowrate.
Note: You can reduce the pump speed from 0.1rpm (or any other minimum displayed unit of speed as selected in the Scrolling section of the Setup menu) to 0rpm by a further press on the **DOWN** key. The pump is still in the running state and the rotation symbol will continue to move. Press the **UP** key to return the pump to the minimum speed.
Note: If a minimum allowed speed has been set in the Set Min Speed section of the Setup menu, the above note on speed reduction to 0rpm does not apply.
- **DIRECTION**: toggles the direction of rotation shown on the display. If the pump is then started by pressing the **START** key, it rotates in the new direction. If the pump is running when **DIRECTION** is pressed, the change takes effect immediately.
- **ENTER**: is used to enter/confirm numeric and menu selections. Also cycles the information shown on the manual mode main screen exactly as **START** does, whether the pump is running or not. See **START**, above.
- **MENU**: causes the main menu to be displayed, from which all aspects of pump setup can be controlled, including the MemoDose facility. See 15. Main menu.

Keypress combinations cause the pump to function as follows:

Note: A number of the controls listed below are shortcuts to commands which are also available through the Main menu. See 15. Main menu.

- **UP** and **DIRECTION** on power-up: toggles the **keypad beep** on and off.
- **START** on power-up: switches on the **Auto-restart** facility. See 16.6 Auto-restart.
- **STOP** on power-up: switches off the **Auto-restart** facility. See 16.6 Auto-restart.
- **STOP** and **DIRECTION** on power-up: allows the user to press **UP** and **DOWN** keys to toggle the sense of remote run/stop control between open=stop and open=run.
- **STOP** and **UP** while the pump is stopped: turns the **display backlight** on.
- **STOP** and **DOWN** while the pump is stopped: turns the **display backlight** off.
- **MAX** and **UP**: sets the pump to maximum allowed speed.
- **MAX** and **DOWN**: sets the pump to minimum allowed speed.
- **DIRECTION** and **DOWN**: interrupts the display to show the pump's ROM ver-

sion for four seconds.

- **START** pressed and held for two seconds: toggles the **keypad lock** on and off. Only the **START** and **STOP** keys are active when keypad lock is on. The padlock icon is displayed.
- **STOP** pressed and held for two seconds: toggles the **keypad lock** on and off. Only the **START** and **STOP** keys are active when keypad lock is on. The padlock icon is displayed.
- **STOP STOP** within half a second: shortcut entry to the MemoDose menu; when in MemoDose, shortcut return to manual mode main screen. See 17. MemoDose.

14.2 Speed

To change the running speed:

- Use the **UP** and **DOWN** keys to change the pump's running speed within limits of 0.1 rpm or other minimum allowed speed and the maximum allowed speed.
Note: You can reduce the pump speed from 0.1 rpm or other minimum allowed speed to 0 rpm by a further press on the **DOWN** key. The pump is still in the running state and the rotation symbol will continue to move. Press the **UP** key to return the pump to the minimum speed.

Note: The maximum allowed speed of the drive defaults to 300 rpm. It is possible to set this limit at any speed up to 360 rpm. It is also possible to set a minimum speed. See 16.7 Set maximum allowed speed and 16.8 Set minimum allowed speed.

14.3 Direction

To toggle the pump's rotation sense:

- Press **DIRECTION** to toggle the pump between clockwise and counter-clockwise rotation.

14.4 Keypad lock

The keypad can be locked to prevent changes to pump speed or other settings, and make it possible only to start or stop the pump. The padlock symbol shows on the display.

- While the pump is running, hold down the **START** key for two seconds. The padlock symbol shows and only the **START** and **STOP** keys function.
- The keypad may also be locked while the pump is stopped. Hold down the **STOP** key for two seconds. The padlock symbol shows and only the **START** and **STOP** keys function.
- To unlock the keypad while the pump is running hold down the **START** key for two seconds. The padlock symbol is removed. If the pump is stopped hold down the **STOP** key until the padlock symbol is removed.

14.5 Keypad beep

The pump keypad can operate silently or indicate a positive key-press with a beep sound.

- To toggle the sound on and off, stop the pump. Turn off the mains power switch at the rear of the pump.
- Depress the **UP** and **DIRECTION** keys while switching on the mains power switch at the rear of the pump.

14.6 To reset defaults

All settings can be re-set to factory defaults.

- Turn off the mains power switch at the rear of the pump.
- Press the **DIRECTION** key while switching on the mains power switch at the rear of the pump. A warning screen is displayed briefly, followed by a screen asking the user to confirm that factory defaults are to be reset.
- Select **Yes** or **No** using the **UP** and **DOWN** keys. Confirm by pressing **ENTER**. If **Yes** was confirmed, the pump resets all user-settable data to default values and displays the manual mode main screen. If **No** was confirmed, no change is made and the manual mode main screen is displayed.

The language of display screens may be reset only by resetting defaults.

14.7 To reset language

The language of display screens is set on initial start-up. To reset language, reset all defaults (see 14.7 To reset defaults).

14.8 Backlight

To turn the display backlight on:

- Depress the **STOP** and **UP** keys together.

To turn the display backlight off:

- Depress the **STOP** and **DOWN** keys together.

See 16.11 Backlight.

14.9 Auto-restart

This pump offers an auto-restart feature. When active on power loss, it will restore the pump when power returns to the operating state it was in when power was lost. It does not operate when powering down in the middle of a dose; when the pump is restarted, it will await a press on the **START** key to begin the interrupted dose again. Auto-restart is retained while the pump is switched off. When the pump starts running look for the ! symbol on the display. This ! symbol indicates that the pump is set for auto-restart.



Do not use auto-restart for more than 100 starts per hour. We recommend remote control where a high number of starts is required.

To turn the auto-restart facility on:

- Turn off the mains power switch at the rear of the pump.
- Depress the **START** key while switching on the mains power switch at the rear of the pump.

To turn the auto-restart facility off:

- Turn off the mains power switch at the rear of the pump.
- Depress the **STOP** key while switching on the mains power switch at the rear of the pump.

14.10 Manual operation and remote digital inputs and outputs

The remote run/stop, direction and leak-detected inputs are operational.

The remote status outputs are all fully functional.

The **STOP** key acts as an emergency stop. The run/stop input will not start the pump in manual mode, but once the **START** key has been pressed, the remote run/stop input will stop and start the pump according to its operational state.

If you invert the operation of the remote run/stop switch to operate as open=stop, you must connect the +5V terminal to the i/p terminal on the Run/stop input connector (J4), to be able to start the pump from the keypad. See 19.6 Run/stop input.

If **STOP** is pressed the remote run/stop switch will have no effect.

You cannot invert the polarity of the remote direction signal.

15 Main menu

15.1 Keypad functions in menu screens

In addition to their functions in other operations, the following keys have specific actions in menu screens:

- **STOP**: In general, **STOP** functions as a “go back” key, taking the user up one menu level without making a change.
- **UP**: The **UP** key is used in menu item selection: it moves a highlight up the menu. When a numerical entry screen is displayed, pressing **UP** increases the number displayed.
- **DOWN**: The **DOWN** key is used in menu item selection: it moves a highlight down a menu. When a numerical entry screen is displayed, pressing **DOWN** decreases the number displayed.
- **ENTER**: The **ENTER** key functions in a similar way to the “enter” key of a personal computer: it confirms key-presses made immediately before. In menu item selection, it triggers the action or display selected from a menu using the **UP** and **DOWN** keys.

Note: Confirmation screens are displayed for 4 seconds. While they are displayed, a single press on any key removes them.

15.2 Main menu entry

The **MENU** key displays the main menu and stops the pump if it is running in Manual mode. It operates at any point in the pump’s activity except where error screens are displayed, where **UP** and **DOWN** keys are used to enter values, or where a PIN is requested.



The main menu offers four options: **Setup**, **MemoDose**, **Pin out details**, and **Exit**. Use the **UP** and **DOWN** keys to make a choice. Press the **ENTER** key to confirm your decision.

Setup

Setup allows the user to set the pump’s operating parameters under 15 headings: Trim, Analogue, Display, Outputs, Remote stop, Auto-restart, Set max speed, Set min speed, Scrolling, Date/time, Backlight, ROM, Language, Defaults, Security code and Exit.

MemoDose

The **MemoDose** facility is used to remember the number of revolutions needed to dispense a previously dispensed volume of fluid, and cause the pump to dispense that volume repeatedly.

Pin out details

Pin out information is not relevant to the 720US IP66/NEMA 4X pumps. Selecting **Pin out details** causes the pump to display a warning screen and redisplay the main menu.

Exit

If **Exit** is selected, the pump returns to its last manual state with the pump stopped.

16 Setup

Entry to the Setup menu is from the Main menu and can be limited to users who correctly enter a three-digit security code. If a security code has been set, selecting **Setup** and confirming with the **ENTER** key causes the pump to display the Security code entry sequence. See 16.15 Security code. If no security code has been set, the pump displays the first of seven screens containing the Setup menu.

The Setup menu

The Setup menu occupies five screens (720UN) or two screens (720SN). The first two of the 720UN are shown here.

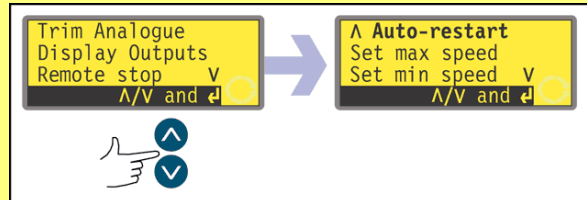

To move from one screen to subsequent screens, repeatedly press **DOWN**. Each item is highlighted in turn until the last item on the screen is highlighted.

A further press on the **DOWN** key displays the next screen of the menu, with the first item highlighted.

Follow the reverse procedure using the **UP** key to move to an item on a previous screen of the menu.

Make a selection using the **UP** or **DOWN** keys and press **ENTER** to confirm your choice.

16.1 Trim

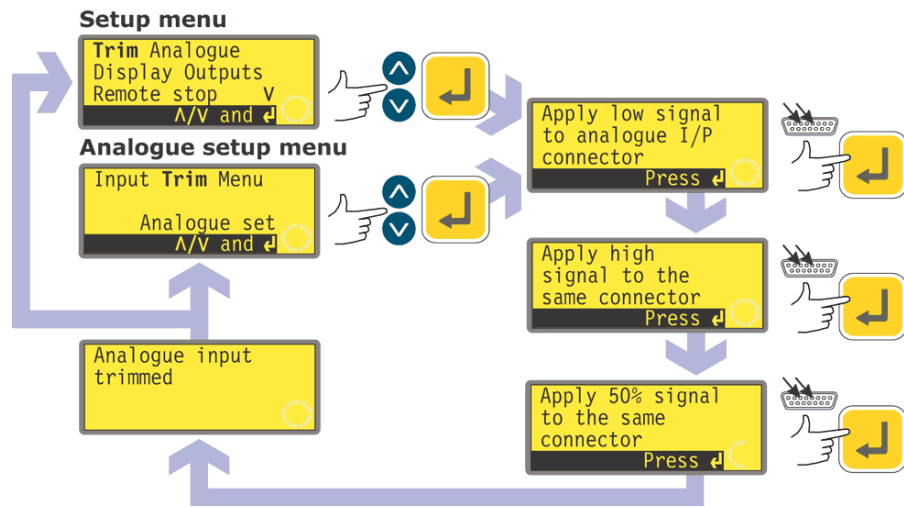

When the pump is under remote control, it tracks an analogue signal from the user's remote control system to the **i/p** terminal of the Analogue 1 connectors at the rear of the pump within the ranges 4-20mA, 0-10V or 1-5V. The **Trim** setup sequence allows the user to customise the process-signal-to-pump-speed calibration. The sequence may be entered directly from the Setup menu or from the Analogue setup menu.

- Select **Trim** from the Setup menu or the Analogue setup menu using the **UP** or **DOWN** keys and press **ENTER** to confirm your choice.
- Apply the low process analogue signal to the i/p terminal of the Analogue 1 connector as instructed in the display. See 16.2 Analogue. While the signal is being applied, press **ENTER** to record the signal as a calibration point.
- Apply the maximum process control signal. While the signal is being applied, press **ENTER** to record the signal as a calibration point.
- Apply 50% of the maximum process control signal. While the signal is being applied, press **ENTER** to record the signal as a calibration point.
- If a mistake is made, press **STOP** at any point in the sequence, and the pump displays the previous screen.
- The final press on **ENTER** causes the pump to display a confirmation screen and then redisplay the screen from which it entered the trim sequence: the Setup menu or the Analogue setup menu.

The pump calculates a linear response from low to mid and from mid to high, and records the results as a new analogue input calibration graph.

If any of the three signals match, a warning screen is displayed before the confirmation screen appears, and the trim is ignored.

Note: By applying the maximum process control signal when the minimum is requested and vice versa, inverted responses can be set up.

Note: Resetting factory defaults clears the trim calibration values.

16.2 Analogue

When the pump is under remote control, it tracks an analogue signal from the user's remote control system to the **i/p** terminal of the Analogue 1 connector at the rear of the pump within the ranges 4-20mA, 0-10V or 1-5V. The **Analogue** option in the Setup menu allows the user to configure the pump to operate with his remote control system.

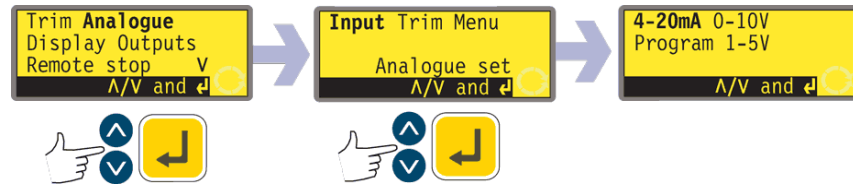

- Select **Analogue** from the Setup menu using the **UP** or **DOWN** keys and press **ENTER** to confirm your choice.
- Three options are displayed: **Input**, **Trim** and **Menu**.

Input allows the user to tell the pump which signal type he will apply, or to choose the program option. If he selects **Program** from the subsequent menu, the user can choose his input type and tell the pump the speeds at which to operate on receiving a low or high process control signal. See 16.2.1 Input speed.

Trim displays the Trim menu, described above. See 16.1 Trim.

Menu returns the user to the first section of the Setup menu. See 16 Setup.

16.2.1 Input speed

- Select **Input** using the **UP** or **DOWN** keys and press **ENTER** to confirm your choice.
- The pump offers three further choices: **4-20mA**, **0-10V** and **1-5V**. Use the **UP** or **DOWN** keys to make a selection and press **ENTER** to confirm your decision.

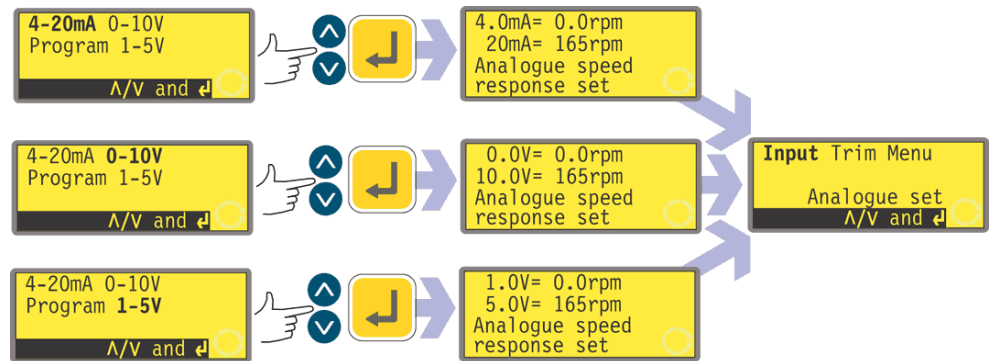

- The pump configures the hardware and factory-set response data and briefly displays a confirmation screen. The user is returned to the Analogue setup display. Example values are shown here.
- Alternatively the user can select **Program** to configure the pump to respond in a user-programmed way to any process signal range within 4-20mA, 0-10V or 1-5V.

Program

- Select Program using the **UP** or **DOWN** keys and press **ENTER** to confirm.
- The pump offers two choices: **mA** and **V** (0-10V). Use the **UP** or **DOWN** keys to make a selection and press **ENTER** to confirm your decision.

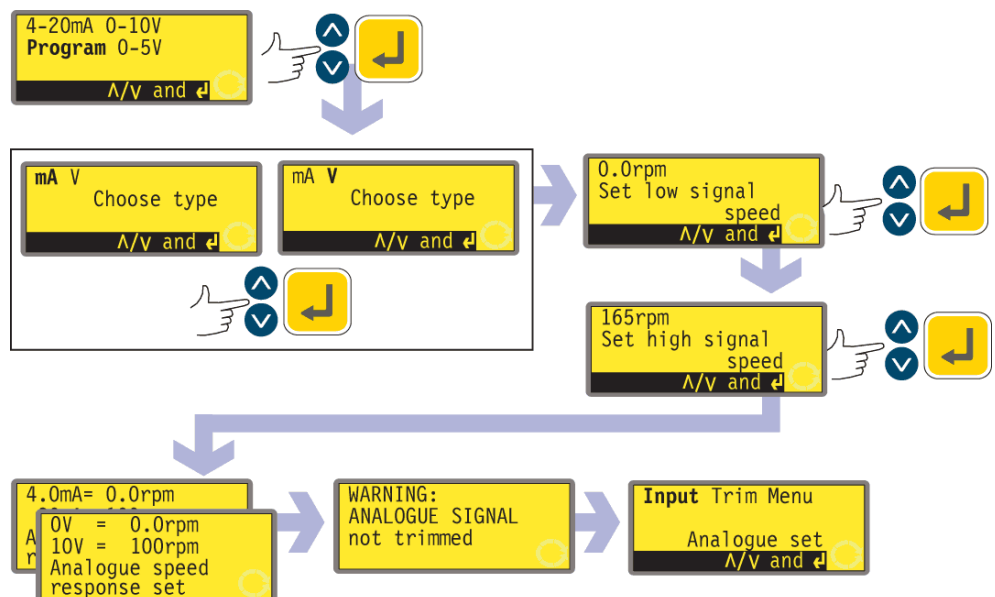

- The pump displays a screen allowing you to set the speed for low signal input (4mA or 0V). Use the **UP** and **DOWN** keys to scroll the display to your chosen speed and press **ENTER** to confirm the figure.

- The pump displays a screen allowing you to set the speed for high signal input (20mA or 10V). Use the **UP** and **DOWN** keys to scroll the display to your chosen speed and press **ENTER** to confirm the figure.
- If a mistake is made, the user may press **STOP** at any point in the sequence (before pressing **ENTER** on the high signal speed screen), and the pump displays the previous screen.
- The final press on **ENTER** causes the pump to configure the hardware and programmed response data. It briefly displays a confirmation screen and a warning that the analogue signal is not trimmed, and returns the user to the Analogue setup menu. Example values are shown here.

16.2.2 Trim

Trim displays the Trim menu, described above. See 16.1 Trim. It is recommended that a trim calibration is always performed to align the pump's response to the actual process analogue signal.

16.2.3 Menu

Menu returns the user to the first section of the Setup menu, described above. See 16 Setup.

16.3 Display

The pump can display two default screens in manual mode: revolutions per minute or flowrate.

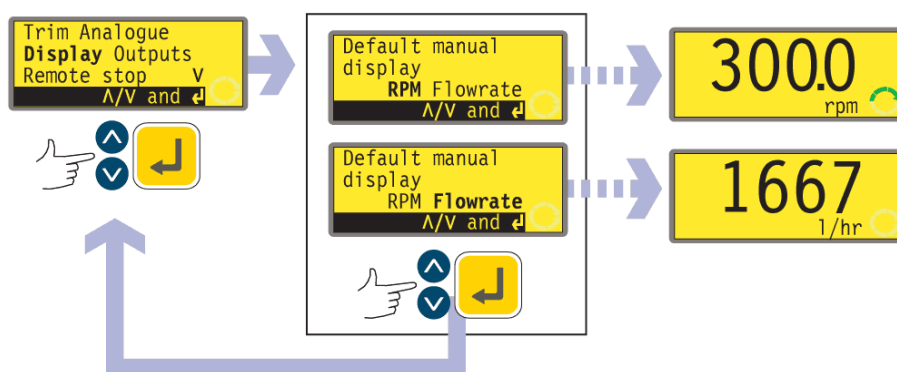

- In the first screen of the Setup menu select **Display** using the **UP** and **DOWN** keys. Press **ENTER** to confirm your choice.
- The pump displays a screen allowing you to choose the format of the manual mode main screen. Use the **UP** and **DOWN** keys to choose and press **ENTER** to confirm your decision.
- The pump redisplay the first screen of the Setup menu.
- When the pump next runs, the manual mode main screen will display pump activity in rpm or l/min, according to your choice. Examples are shown here.

Note: A third display option is available: showing rpm and flowrate. See Alternatively, next.

Alternatively ...

- In the manual mode main screen, repeatedly press **ENTER** to cycle the display between rpm, flowrate or combined, according to your choice. This cycle operates if the pump is running and if it is stopped. While the pump is running, you can cycle the display in the same way by repeatedly pressing **START**. In both cases, if you have not calibrated the pump since switching it on, a warning screen is displayed for 4 seconds before the flowrate screen appears. The warning does not appear if the display formats are cycled again, unless the pump has been switched off.
- The pump redisplay the first screen of the Setup menu.

16.4 Outputs

The pump offers four relay status outputs. See 12 Switching the pump on for the first time for initial start-up defaults. Each of six parameters can be configured to any output, or more than one output.

The parameters are:

Run/stop

Provides a status output to indicate whether the pumphead is in a running or stopped condition. When running at 0 rpm, the run/stop output indicates running.

Direction

Provides a status output to indicate which direction the pump is set to run in.

Auto / man

Provides a status output to indicate whether the pump is in analogue control mode or manual control mode.

General alarm

Provides an alarm output when any system error condition occurs except: leak detected; analogue signal out of range; analogue over-signal; analogue no signal.

Leak detected

When used with a leak detector, this output provides an alarm when the pump has been automatically switched off following tube failure.

Head

Provides an alarm when the pumphead track is open. If it is running, the pump will stop.

Outputs 1-4 are available as single-pole change-over relay contacts: Relay 1, 2, 3 and 4. Connect to the normally open or normally closed contacts of the relay as required and configure the pump's software accordingly. See below in this section.

Note: The maximum load on the relay contacts of this pump is 1250VA.

Important: Never apply mains power above 130VAC to the relays.

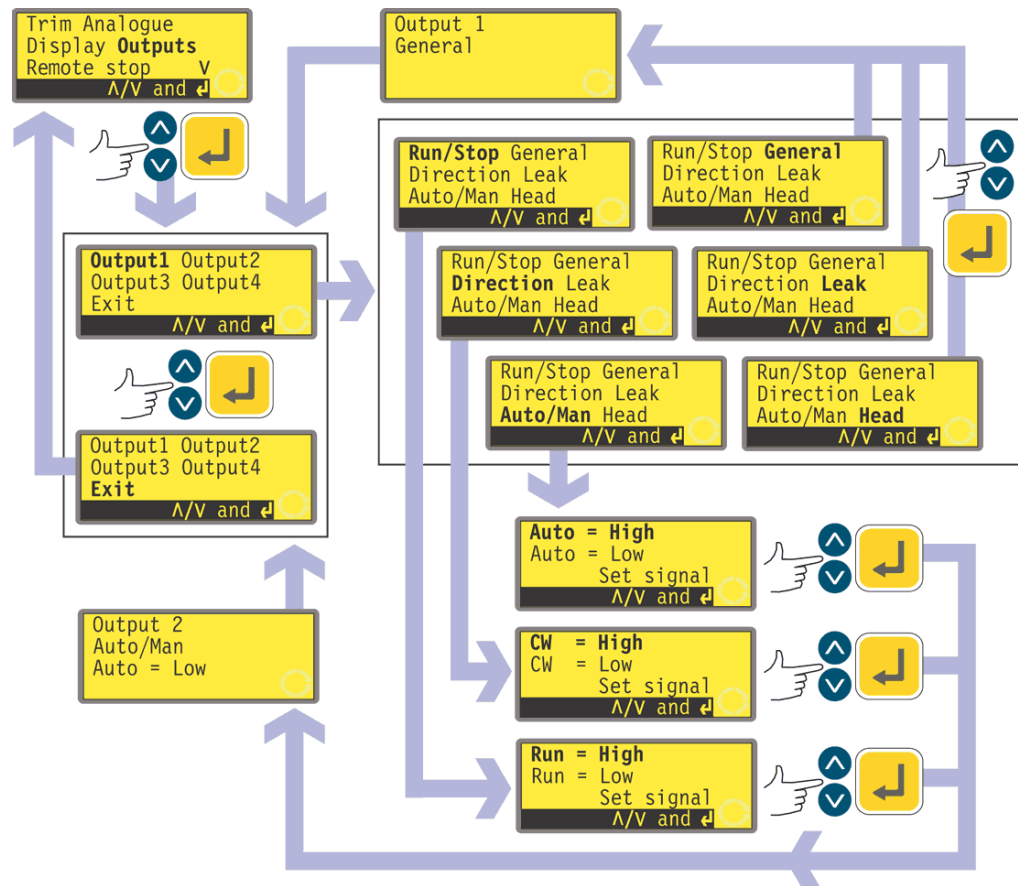

- In the first screen of the Setup menu select **Outputs** using the **UP** and **DOWN** keys. Press **ENTER** to confirm your choice.
- The pump displays a screen allowing you to configure each of the four outputs, or to exit this menu. Use the **UP** and **DOWN** keys to choose and press **ENTER** to confirm your decision.
- If **Output 1** is chosen, the pump displays the six options.
 - Selecting **General**, **Leak** or **Head** using the **UP** and **DOWN** keys and confirming the choice by pressing **ENTER** configures that option to Output 1, displays a confirmation screen, and returns the user to the Output selection screen.
 - Selecting **Run/Stop**, **Direction** or **Auto/Man** using the **UP** and **DOWN** keys and confirming the choice by pressing **ENTER** displays screens allowing the user to configure Run to **High** or **Low**, Clockwise to **High** or **Low**, and Auto to **High** or **Low** respectively. Choose using the **UP** and **DOWN** keys and press **ENTER** to confirm. The option chosen is configured to Output 1. The pump displays a confirmation screen, and returns the user to the Output selection screen.
- The user can configure **Output 2**, **Output 3** and **Output 4** in the same way, or choose **Exit**.
- If **STOP** is pressed during configuration, the previous setting for the output is retained and the pump redisplay the Output selection screen.
- If **Exit** is chosen, the pump returns the user to the third screen of the Setup menu.

16.5 Remote stop

The pump can be started and stopped with a remote switch between the 5V terminal and the i/p terminal of the Run/stop input, using an open=run or open=stop command sense. It also operates with a logic input between 5V and 24V on the i/p terminal of the Run/stop input. Disabling the remote stop control does not disable other remote controls.

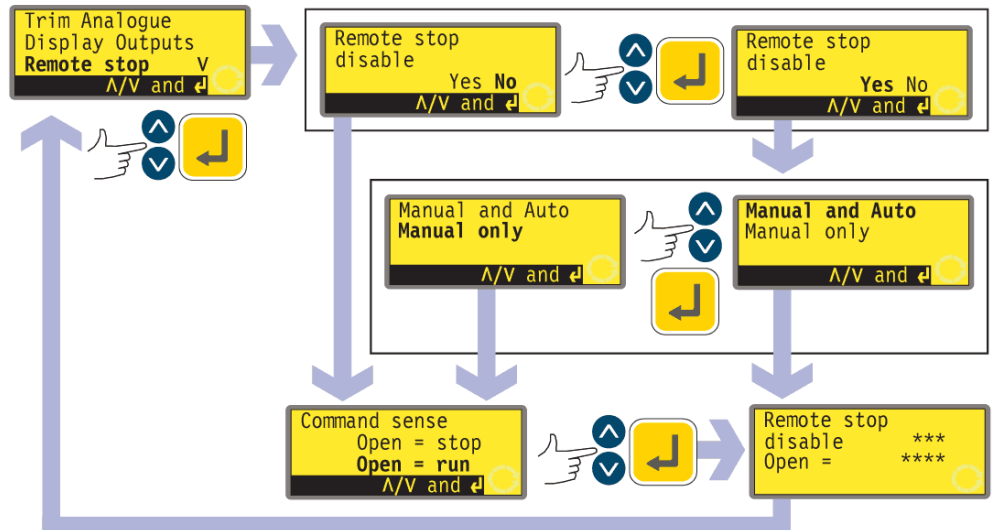

- In the first screen of the Setup menu select **Remote stop** using the **UP** and **DOWN** keys. Press **ENTER** to confirm your choice.
- The pump displays a screen allowing the user to disable the remote stop feature. Use the **UP** and **DOWN** keys to choose **Yes** or **No** and press **ENTER** to confirm the decision.
- If **No** is chosen, the pump asks the user to make a further choice, according to whether the pump is required to run on an open or closed remote switch: **Open=stop** or **Open=run**. Choose using the **UP** and **DOWN** keys and press **ENTER** to confirm. The pump briefly displays a confirmation screen and returns the user to the first screen of the Setup menu.
- If **Yes** is chosen, the pump asks the user whether the remote stop feature is to be disabled fully (for both manual and auto operation), or only for manual operation, leaving remote stop functioning when the pump is operating in auto mode. Choose using the **UP** and **DOWN** keys and press **ENTER** to confirm. If manual and auto was chosen, the pump briefly displays a confirmation screen (an example is shown here) and returns the user to the first screen of the Setup menu. If manual only was chosen, the pump asks the user to make a further choice, according to whether the pump (with remote control available in auto mode only) is required to run on an open or closed remote switch: **Open=stop** or **Open=run**. Choose using the **UP** and **DOWN** keys and press **ENTER** to confirm. The pump briefly displays a confirmation screen (an example is shown here) and returns the user to the first screen of the Setup menu.
- **Note:** The confirmation screen indicates whether Remote stop is enabled or disabled, and displays the command sense of the remote control switch **even if Remote stop has been disabled**. This allows the command sense to be displayed if remote switching is disabled.



Even with the remote stop function disabled, the pump could still start if the remote auto/manual toggle input is used to toggle the pump into analogue mode.

Alternatively ...

- To toggle the sense of the remote run/stop control between open=stop and open=run: stop the pump. Turn off the mains power switch at the rear of the pump.
- Hold down the **STOP** key and the **DIRECTION** key, and turn on the mains power switch.

16.6 Auto-restart

The pump offers an auto-restart feature. If active on power loss, it restores the pump when power returns to the operating state it was in when power was lost. It does not operate when powering down in the middle of a dose: when the pump is restarted, it will await a press on the **START** key to begin the interrupted dose again. Auto-restart is retained while the pump is switched off. When the pump starts running, look for the **!** symbol on the display. This symbol indicates that the pump is set for auto-restart.

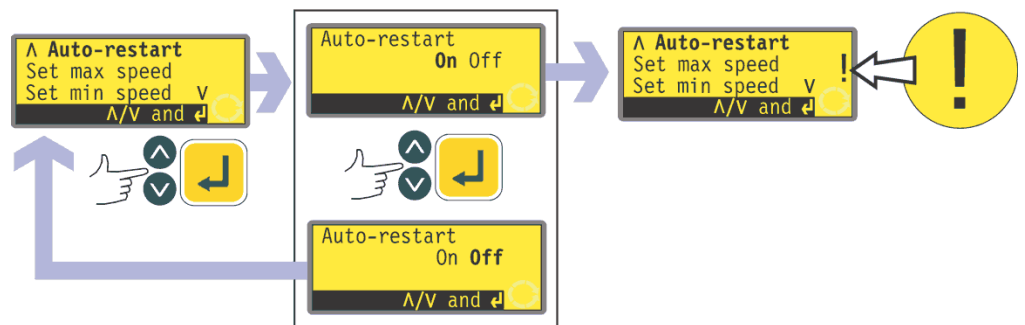

- In the second screen of the Setup menu select **Auto-restart** using the **UP** and **DOWN** keys. Press **ENTER** to confirm your choice.
- The pump displays a screen allowing the user to activate auto-restart. Use the **UP** and **DOWN** keys to choose **On** or **Off** and press **ENTER** to confirm the decision.
- If **Off** is chosen, the pump returns the user to the second screen of the Setup menu. The auto-restart facility will not operate.
- If **On** is chosen, the pump returns the user to the second screen of the Setup menu, where an exclamation mark (**!**) is now visible. This mark confirms that the auto-restart feature is in place and will operate the next time power is lost and restored.

Alternatively ...

- Stop the pump. Turn off the mains power switch at the rear of the pump.
- Hold down the **START** key and turn on the mains power switch. The **!** symbol shows on the display.
- Start the pump. If the mains supply is interrupted the pump will automatically restart when the mains power returns.
- To remove auto-restart switch off the mains power at the rear of the pump. Hold down the **STOP** key and turn the mains power switch on. The **!** symbol does not appear.



Do not use auto-restart for more than 100 starts per hour. We recommend remote control where a high number of starts is required.

16.7 Set maximum allowed speed

The maximum allowed speed of the drive defaults to 300 rpm. It is possible to set this limit at any speed down to 1rpm as long as the minimum allowed speed is at least 1 rpm less, or up to 360 rpm.

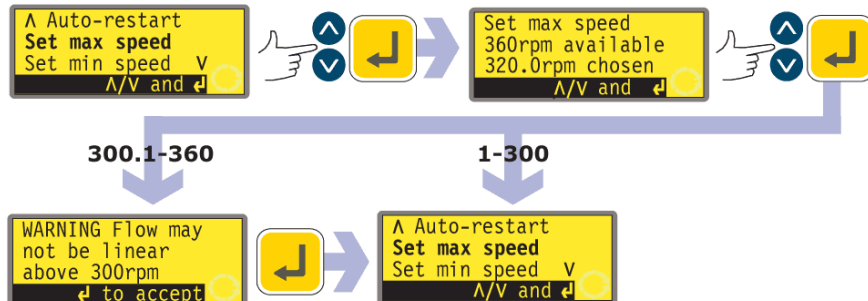

- In the second screen of the Setup menu select **Set max speed** using the **UP** and **DOWN** keys. Press **ENTER** to confirm your choice.
- The pump displays a screen allowing the user to set the maximum speed of the pump equal to or lower than the maximum available. Use the **UP** and **DOWN** keys to set the maximum allowed speed and press **ENTER** to confirm the figure.
- The pump returns the user to the second screen of the Setup menu, via a warning screen requiring the user to press **ENTER** if he selected a speed greater than 300 rpm.

Note: Maximum allowed speed limits speed under manual or analogue control.

16.8 Set minimum allowed speed

The minimum allowed speed of the drive defaults to 0.1 rpm. It is possible to set this limit at any speed up to 359 rpm, as long as the maximum speed is at least 1 rpm greater.



- In the second screen of the Setup menu select **Set min speed** using the **UP** and **DOWN** keys. Press **ENTER** to confirm your choice.
- The pump displays a screen allowing the user to set the minimum speed of the pump equal to or higher than the minimum available. Use the **UP** and **DOWN** keys to set the minimum allowed speed and press **ENTER** to confirm the figure.
- The pump returns the user to the second screen of the Setup menu.

Note: Minimum allowed speed limits speed under manual or analogue control.

Note: You can reduce the speed from the minimum set speed to 0 rpm by a further press on the **DOWN** key.

16.9 Scrolling

In use, the pump's speed can be set, up to the maximum allowed speed and down to the minimum allowed speed, by pressing the **UP** and **DOWN** keys.

In the Scrolling section of the Setup menu, the **UP** and **DOWN** keys allow the speed options to be set in increments of the user's choice: one-tenth of a revolution per minute; one half of a revolution per minute; one, two, five or ten revolutions per minute (or their equivalents in flow rate if the pump has been configured to display its performance in units of flow). Each press on **UP**, for example, offers a speed one increment greater than the current speed.

Note: For 0.1rpm, 0.5rpm and 1rpm settings, the increments increase progressively as long as the **UP** or **DOWN** key is continually held down.



- In the third screen of the Setup menu select **Scrolling** using the **UP** and **DOWN** keys. Press **ENTER** to confirm your choice.
- The pump displays a screen allowing the user to set the **UP** and **DOWN** keys' scrolling increment. Use the **UP** and **DOWN** keys to choose **0.1**, **0.5**, **1.0**, **2.0**, **5.0** or **10.0**. Press **ENTER** to confirm your choice.
- The pump returns the user to the third screen of the Setup menu.

Note: If the maximum allowed speed has been set to a figure which is not a multiple of the chosen increment, the last active press on **UP** raises the speed to that maximum rather than to the next multiple of the chosen increment. Similarly, if the pump is running at a speed which is not a multiple of the chosen increment, the first press on **UP** raises the speed to the next multiple of the chosen increment.

16.10 Date and time

The pump's real-time clock can be set with the date and time.



- In the third screen of the Setup menu select **Date/time** using the **UP** and **DOWN** keys. Press **ENTER** to confirm your choice. The pump displays any previous setting.
- If the setting displayed is correct, press **ENTER**. The pump redisplay the third screen of the Setup menu.
- If you wish to change the setting, use the **UP** and **DOWN** keys to enter the current date (two digits), month (three letters), year (four digits), hour, minute and second (all two digits), pressing **ENTER** to confirm each one.
- When **ENTER** is pressed to confirm the seconds, the pump redisplay the third screen of the Setup menu.

16.11 Backlight

The pump's display can be illuminated or not according to choice.

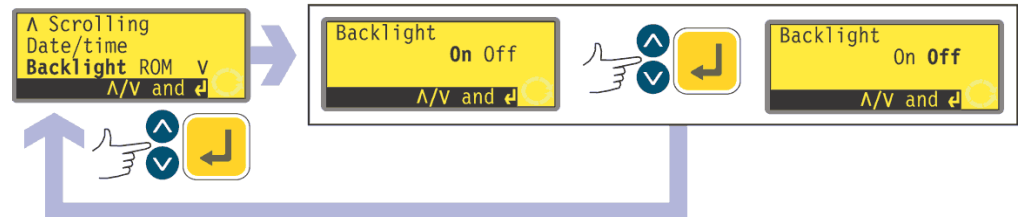

- In the third screen of the Setup menu select **Backlight** using the **UP** and **DOWN** keys. Press **ENTER** to confirm your choice.
- The pump displays a screen allowing the user to switch the display backlight on or off. Use the **UP** and **DOWN** keys to choose **On** or **Off** and press **ENTER** to confirm the decision.
- The pump returns the user to the third screen of the Setup menu. The display is now illuminated or not according to the user's decision.

Alternatively ...

- To turn the backlight off: press **STOP** and **DOWN** together.
- To turn the backlight on: press **STOP** and **UP** together.

16.12 ROM

The pump can display its software version, model number and pump speed.



- In the third screen of the Setup menu select **ROM** using the **UP** and **DOWN** keys. Press **ENTER** to confirm your choice.
- The pump displays the software version, model number and the maximum set pump speed for four seconds (an example is shown here), then returns the user to the third screen of the Setup menu. It also displays a checksum: CHK 123, for example. This may be required if reporting pump performance to the Watson-Marlow service department.

Alternatively ...

Press **DIRECTION** and **DOWN** together to interrupt the display and show the pump's ROM version for four seconds.

16.13 Language

The pump can be set to operate in several languages.

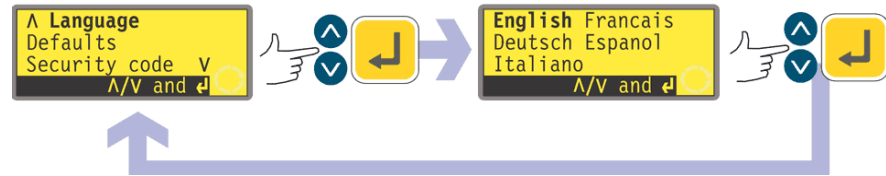

- In the fourth screen of the Setup menu select **Language** using the **UP** and **DOWN** keys. Press **ENTER** to confirm your choice.
- In the next screen, choose a language using the **UP** and **DOWN** keys. Press **ENTER** to confirm your choice. The pump redisplayes the fourth Setup screen in your chosen language. All screens will subsequently appear in your chosen language.

16.14 Defaults

All the pump's user-set data can be reset to factory defaults.

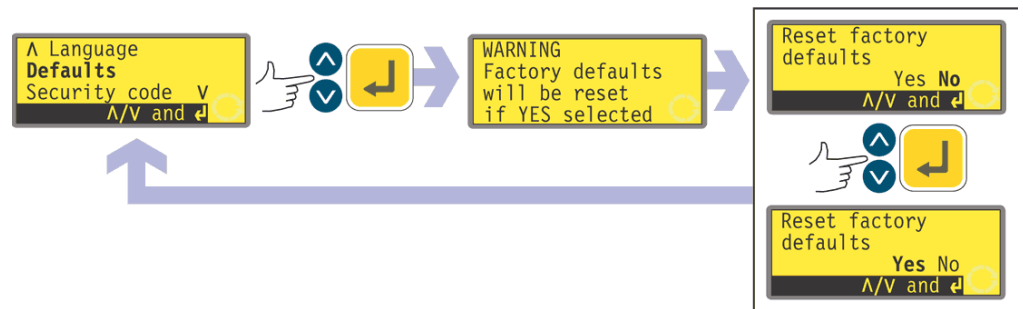

- In the fourth screen of the Setup menu select **Defaults** using the **UP** and **DOWN** keys. Press **ENTER** to confirm your choice.
- A warning is displayed for four seconds, and the pump asks the user to confirm that factory defaults are to be reset. Use the **UP** and **DOWN** keys to choose **Yes** if you wish the pump to reset all user-set data back to factory defaults (see 12 Switching the pump on for the first time); or **No** if you do not wish to do this. Press **ENTER** to confirm your decision. If **Yes** was chosen, the pump redisplayes the fourth Setup screen. Switch the pump off and then on again to complete the defaults reset. If **No** was chosen, the pump makes no changes to its setup and redisplayes the fourth Setup screen.

16.15 Security code

Access to the pump's Setup menu can be restricted to those who correctly enter a three-digit security code. See 16 Setup.

The code must first be set.

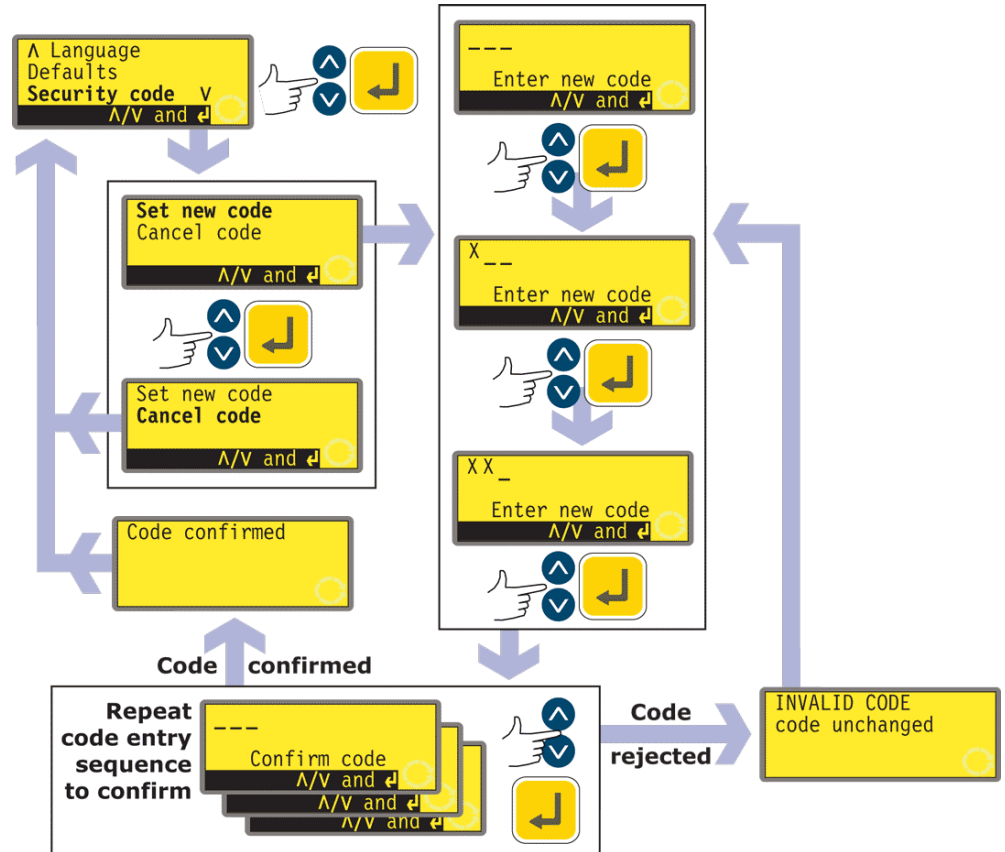

- In the fourth screen of the Setup menu select **Security code** using the **UP** and **DOWN** keys. Press **ENTER** to confirm your choice.
- A screen is displayed inviting the user to set a new code or, if a code is already set, cancel it. Use the **UP** and **DOWN** keys to choose **Set new code** or **Cancel code**. If no code is in place, no option to cancel a code will be displayed. Press **ENTER** to confirm your decision.
- If **Cancel code** is chosen, security protection is removed and the user is returned to the fourth Setup screen.
- If **Set new code** is chosen, the pump displays a screen with three blank spaces for digits and the instruction "Enter new code". Use the **UP** and **DOWN** keys to make your choice of the digits 0-9 for the first digit. Press **ENTER** to confirm. Repeat for the second digit. Repeat for the third digit. The final press on **ENTER** causes the pump to display a similar three-digit entry screen and the instruction "Confirm code".
- Repeat the digit-entry sequence.
- If the second three-digit code entered differs from the first, the pump will briefly display an error message and redisplay the first digit-entry screen.
- If the codes tally, the pump will briefly display a confirmation message and redisplay the fourth Setup screen. Access to the Setup menus is now protected by the new security code.
- If **STOP** is pressed during code entry, the pump returns the user to the fourth Setup screen. If **STOP** is pressed during code confirmation, the pump returns the user to the first digit-entry screen.

Note: If a code has been set but forgotten, it is still possible to access the Setup screens to cancel the code or reset it to another three-digit number. Contact your supplier or Watson-Marlow Technical support for the bypass sequence.

16.16 Exit



- In the fifth screen of the Setup menu **Exit** is highlighted. Press **ENTER**.
- The user is returned to the main menu.

17 MemoDose and calibration

Note: This menu area also gives access to flow rate calibration.

Each time the pump is started by pressing **START**, it records the number of pump-head revolutions which occur until **STOP** is pressed. The number of revolutions is proportional to the volume of fluid which has been dispensed: the dose. The MemoDose facility allows the user to repeat-dose a precise volume of fluid. To do so, a quantity of fluid must be dispensed as the master dose which the MemoDose facility can repeat exactly or proportionately.

To dispense a master dose

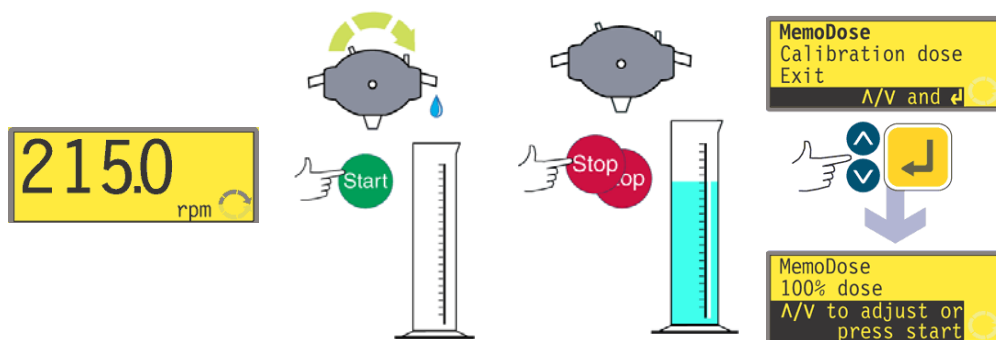

- In the manual mode main screen, set the appropriate pump speed and direction using the **UP** or **DOWN** keys and the **DIRECTION** key. An example is shown here. A slower speed may make it easier for the user to measure accurately - though it may not represent the duty condition.
- Place a suitable measuring vessel under the pump delivery tube.
- Press **START**. The pump runs and fluid is pumped into the vessel.
- When the required volume of fluid has been dispensed, it is necessary to stop the pump and display the MemoDose screen. This can be achieved in several ways.
 - 1 Press the **STOP** key twice within half a second. The pump stops and immediately displays the MemoDose screen.
 - OR... 2 Press the **STOP** key once. The pump stops. (This may make it easier to ensure that the quantity of fluid that has been dispensed is sufficiently precise.) Then press the **STOP** key twice within half a second. The pump displays the MemoDose screen.

OR... 3 720UN Press the **STOP** key. The pump stops. Press the **MENU** key. Use the **UP** or **DOWN** keys to select **MemoDose**. Press **ENTER** to confirm. The pump displays the MemoDose screen.
 OR... 4 , 720SN Press the **MemoDose** key

To repeat the dose

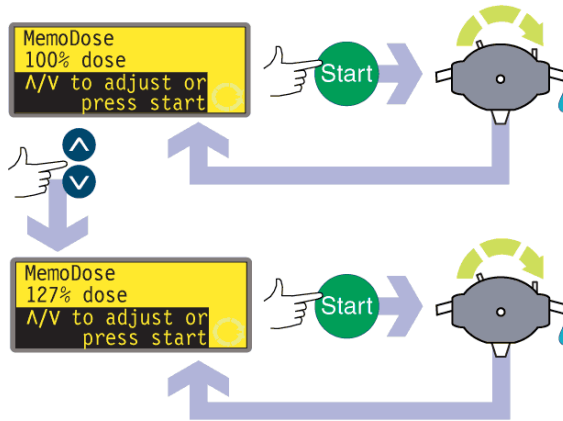

- The pump has recorded the number of pumphead revolutions required to dispense the master dose. If the volume of fluid in the measuring vessel is the volume required, press **START** to repeat the dose.
- If the volume of fluid in the measuring vessel differs from the volume required, the percentage may be adjusted within the limits 1% to 999% of the master dose. Use the **UP** or **DOWN** keys to alter the percentage. Press **START** to dispense the new dose.
- The display counts down as the dose proceeds and stops when the dose is complete.
- If **STOP** is pressed during dosing, the pump stops and returns the user to the MemoDose percentage screen.

Press the **STOP** key twice within half a second if you wish to exit MemoDose and return to manual operation.

17.1 Changing dosing speed

The user must exit MemoDose in order to change pump speed. After returning to MemoDose, the pump dispenses the previous dose size at the new speed.

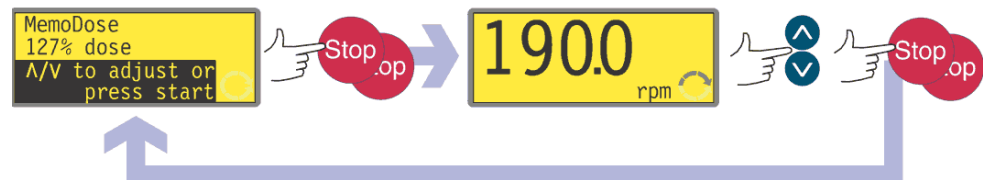

- Press the **STOP** key twice within half a second. The pump displays the manual mode main screen.
- **Do not start the pump. Doing so erases the previously recorded master dose and replaces it in the pump’s memory with the current, unmea-**

asured dose. Adjust the speed showing on the display using the **UP** or **DOWN** keys.

- Press the **STOP** key twice within half a second to return to MemoDose. The display shows the previous percentage dose size. The pump will dose at the new speed.

Note: To retain the MemoDose value through a power interruption the pump must be in auto-restart mode. The dosing cycle will resume at the start of a dose and wait for **START** to be pressed, with the MemoDose percentage screen displayed. See 16.6 Auto-restart.

17.2 Footswitch operation and other remote inputs and outputs with MemoDose

A footswitch can be used to trigger MemoDose dispensing as a hands-free alternative to pressing **START**.

To operate MemoDose with a footswitch, briefly press the footswitch while the MemoDose percentage screen is displayed.

The remote run/stop input is operational. If a dose is interrupted by a remote stop signal, the dose will continue from where it stopped when the state is changed to run.

Remote direction control is disabled. The leak-detection input is operational. All status outputs are operational.

Note: The keypad lock feature is particularly useful to prevent inadvertent dose changes while using the MemoDose facility. Keypad lock continues to operate in MemoDose if previously enabled; it can also be enabled while in MemoDose mode. See 14.5 Keypad lock.

17.3 Flow calibration

The pump can display flowrate in millilitres per minute as well as speed in revolutions per minute.

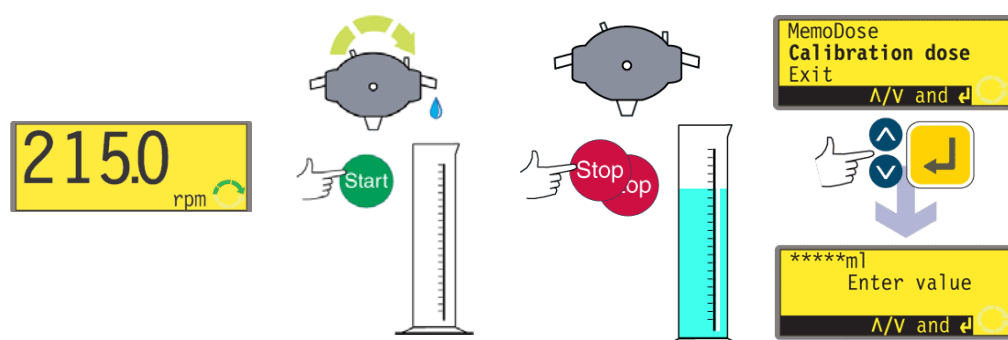

- In the manual mode main screen, set the appropriate pump speed and direction using the **UP** or **DOWN** keys and the **DIRECTION** key. A slower speed may make it easier for the user to measure accurately - though it may not represent the duty condition.

- Place a suitable measuring vessel under the pump delivery tube.
- Press **START**. The pump runs and fluid is pumped into the vessel. The volume pumped is not important; but the greater the volume, the more accurate the flow-per-revolution calculation will be. We suggest that the pumphead be run for at least 10 revolutions, and at least 20 when small-bore pumping tube is used.
- When a volume of fluid has been dispensed, it is necessary to stop the pump and display the Calibration dose screen. This can be achieved in several ways.
 - 1 Press the **STOP** key twice within half a second. The pump stops and immediately displays the MemoDose/Calibration screen. Use the **UP** or **DOWN** keys to select **Calibration dose**. Press **ENTER** to confirm.
 - OR... 2 Press the **STOP** key once. The pump stops. (This may make it easier to ensure that the quantity of fluid that has been dispensed is sufficiently precise.) Then press the **STOP** key twice within half a second. The pump displays the MemoDose/Calibration screen. Use the **UP** or **DOWN** keys to select **Calibration dose**. Press **ENTER** to confirm.
 - OR... 3 **720UN** Press the **STOP** key. The pump stops. Press the **MENU** key. Use the **UP** or **DOWN** keys to select **MemoDose**. Press **ENTER** to confirm. The pump displays the MemoDose/Calibration screen. Use the **UP** or **DOWN** keys to select **Calibration dose**. Press **ENTER** to confirm.
 - OR... 4 **720SN** Press the **MemoDose** key. The pump displays the MemoDose/Calibration screen. Use the **UP** or **DOWN** keys to select **Calibration dose**. Press **ENTER** to confirm.
- Measure the volume of fluid pumped. Make a note of the volume.
- The pump has recorded the number of pumphead revolutions required to pump the volume of fluid measured.
- The calibration dose screen is displayed. It shows a four-digit number of millilitres, and the instruction: "Enter dose value". The number displayed is the number which was entered the previous time the pump was calibrated (or the default figure).

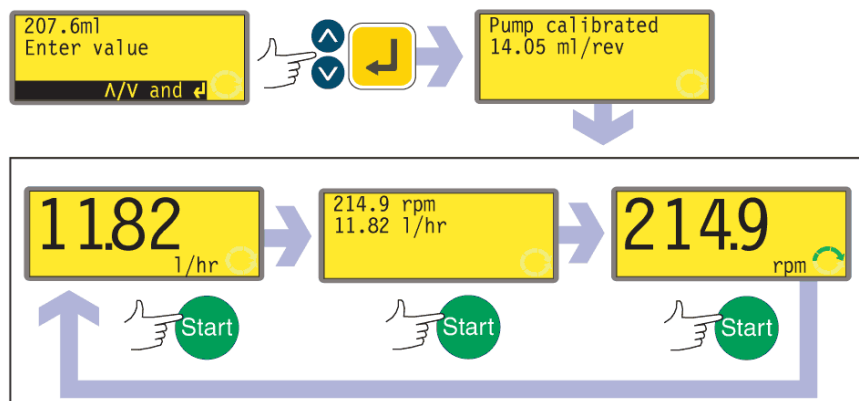

- Use the **UP** and **DOWN** keys to enter the measured volume of fluid pumped. Press **ENTER** to confirm.
- The pump calculates the volume of fluid pumped for each pumphead revolution. The value from this calculation is saved for use in manual mode displays.
- The pump displays a confirmation screen for four seconds, and returns the user to the manual mode main screen, with millilitres per minute shown.
- The pump can now display millilitres per minute, revolutions per minute, or both. Press the **START** key while the pump is running to cycle through the three display options. Example values are shown here.

Note: Always recalibrate after changing pump tubes, fluid, or any connecting pipework. It is also recommended that the pump is recalibrated periodically to maintain accuracy.

17.4 Exit

To return to the manual mode main screen select **Exit** using the **UP** and **DOWN** keys. Confirm by pressing **STOP**.

18 Exit

Press **Exit** in the Main menu to return to the Manual mode main screen.

19 Automatic control wiring using the 720N SCADA module

Interfacing the pump with other devices is by means of screw-terminal connectors within the 720N SCADA module at the rear of the pump. Suitable cable must be passed into the module through one or more watertight cable glands and connected appropriately. The module must be removed to allow this.



It is important to check that the pump's voltage setting matches the supply. The voltage selection switch is on the rear panel of the drive. The module must be removed (and refitted) to allow it to be checked.

19.1 720N SCADA module removal and replacement

To remove the 720N SCADA module:

The module is secured to the back of the drive unit by six M5x12 Pozidriv counter-sunk stainless steel screws.



When the 720 SCADA module has been removed, a USB socket will be seen in the rear of the pump. This socket is for use during manufacture and manufacturer servicing. It is not for auto control. Do not attempt to use it.

- Remove the six screws using a suitable crosspoint screwdriver, leaving the top centre screw until last. Even when all screws have been removed, the sealing strip may cause the module to adhere to the drive. If so, a gentle tap will free it. Do not use a tool to lever it off.
- The sealing strip should be retained within its channel on the face of the module. The transparent on/off switch cover should be retained on its flange on the face of the module. Check the integrity of the seal and the transparent on/off switch cover. If either is damaged, it must be renewed to maintain ingress protection.
- If necessary, unplug the two 25-way D-connectors linking the module to the pump drive. If necessary, remove the module's earth link from the back of the drive. However, the link is long enough to allow the module to fold back to give access to the circuit board inside and to the back of the drive.

To replace the 720N SCADA module:

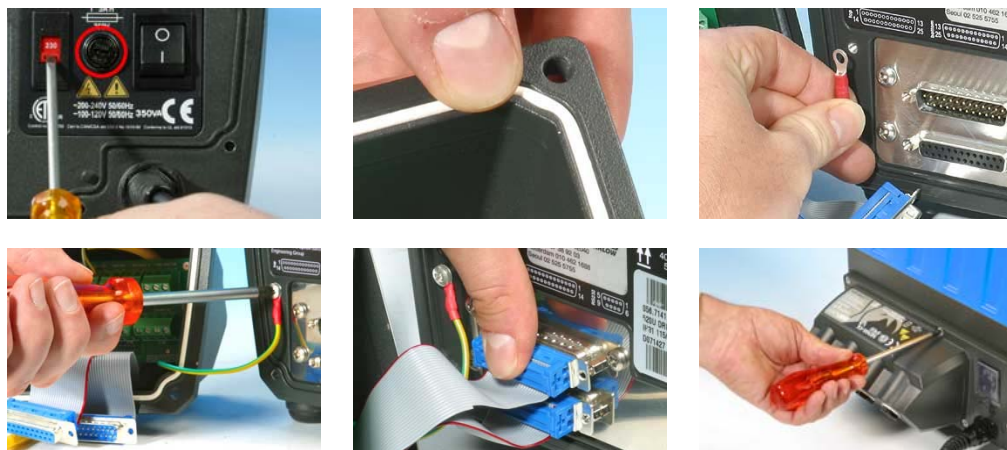

- Check that the fuse in the fuseholder (ringed) does not need to be replaced. Check that the voltage selector switch is correctly set.
- Check that the sealing strip is fully in its channel on the face of the module.
- Attach the module's earth link wire. Replace and tighten its screw to 2Nm.
- Push home the female (upper) and male 25-way D-connectors.
- Hold the module in place. Do not disturb the seal or pinch the earth link wire or D-connector ribbon cables, and screw in the retaining screws (top centre first). Tighten to 2.5Nm.

Note: The 720N SCADA module must be properly fitted using all six screws. Without them, the screw holes may corrode and IP66 (NEMA4X) protection will be compromised.

19.2 Wiring up

It is the user's responsibility to ensure the pump's safe and reliable operation under remote and automatic control.

This pump's 0V lines are commoned and mains transformer-isolated from ground (floating ground). It can be connected to isolated 0V or grounded 0V interfaces.

Cable entry to the module is via up to four watertight cable glands. These may be fitted in place of the plugs which seal the module when the pump is shipped.

The number of glands needed depends on the number of connection cables required and the convenience of the installer. As standard, four M16 cable glands are provided with the pump.

Recommended control cables must be used for the terminal blocks: metric = 0.14sq mm - 2.5sq mm solid and 0.14sq mm - 1.5sq mm stranded. USA = 26AWG - 14AWG solid and 26AWG - 16AWG stranded. Cable: circular. Max/min outside diameter to ensure a seal when passed through the standard gland: 9.5mm-5mm. **The cable**



The recommended cable and cable glands must be used for the IP66 (NEMA 4X) version of this pump; otherwise ingress protection may be jeopardised.

section must be circular to ensure a seal.

For EMC protection, shielded control cable should be used. The shielding should be terminated to one of the pcb mounting screws or to the adjacent spade connection (where fitted).

For improved EMC protection in extremely noisy environments, shielded cable may be used in conjunction with watertight EMC metal cable glands. These must be earthed to the module by adding an M16x1.5 nut with serrated edges to ensure proper contact with the inside of the module. It is necessary to remove the module's circuit board to access the interior of the module: it is held in place by two fixing screws which can be removed and replaced with a cross-point screwdriver. Take normal anti-static precautions when handling printed circuit boards.

Suitable cables for general-purpose use: 300V with extra premium grade PVC jacket with good flame and moisture resistance.

Suitable cables for industrial use: 300V extra-rugged polyurethane grade jacket with resistance to oils, fuels, solvents and water.

For convenience of wiring more than 8 conductors per cable may be awkward to handle. Only two appear in the illustrations here, for clarity.

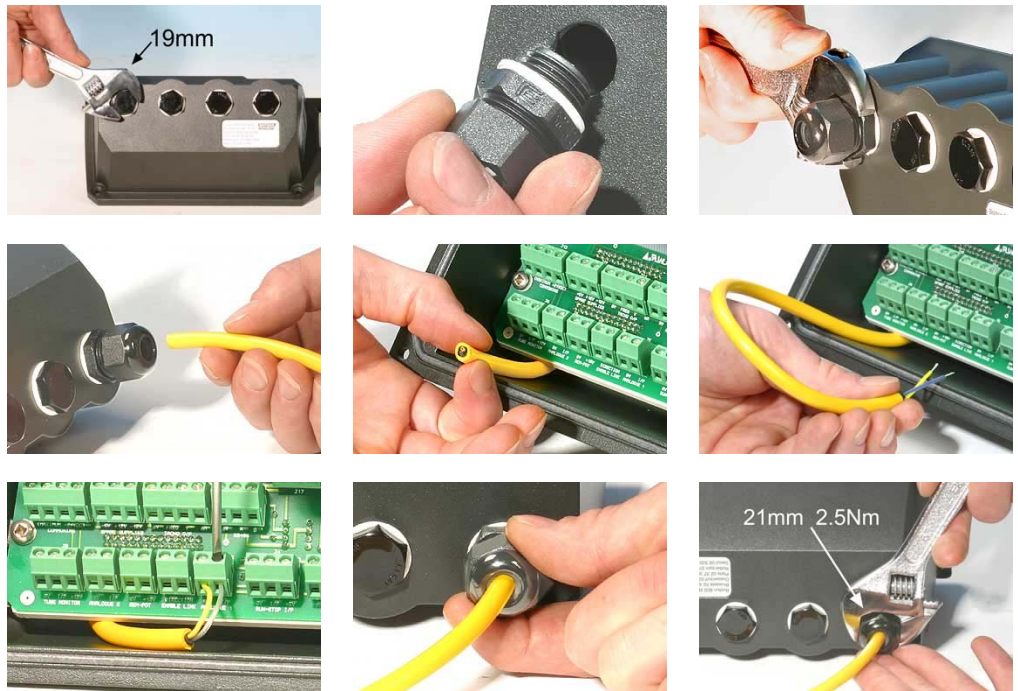

- Use a 19mm spanner to unscrew the sealing plug. Discard the nylon sealing washer.
- Screw in one of the supplied M16x1.5 cable glands in place of the plug, using the new nylon sealing washer supplied. Tighten the gland to 2.5Nm to ensure a seal, using a 21mm spanner. If a different gland is used, it must be watertight to IP66.
- Loosen the gland cap (do not remove it) and pass the cable in through the gland. When it has passed through the gland, continue to push the cable through.
- The inside of the module is shaped to guide the cable past the printed circuit board inside. Continued pushing will feed in enough cable to grip inside the module with the fingers.
- Pull through sufficient cable to reach the connectors required. Leave a little

slack.

- Strip the outer sheath as necessary and remove 5mm of insulation from the conductors. No tinning or ferrule is required. Note: If very stiff or large-diameter cable is used, it may be convenient to strip the outer sheath before passing the cable's conductors through the gland. However, to ensure a seal, cable with an undamaged sheath must be present within the gland when it is tightened.
- Twist a suitable length of the cable screen. Loosen one of the pcb retaining screws and wind the shielding round it. Secure the screen by refastening the screw. Alternatively, secure the cable screen to the adjacent spade connection (where fitted).
- Push the bared conductor into the square hole in the connector. When the conductor is fully in, tighten the retaining screw to hold it in place.
- When all conductors are in position, use a 21mm spanner to tighten the gland cap to 2.5Nm to ensure a seal. Alternatively, tighten the gland by hand until it is finger-tight and use a spanner to tighten it further by one-half a turn.

Do not strap the control and mains power cables together.

720N SCADA module pcb connectors:

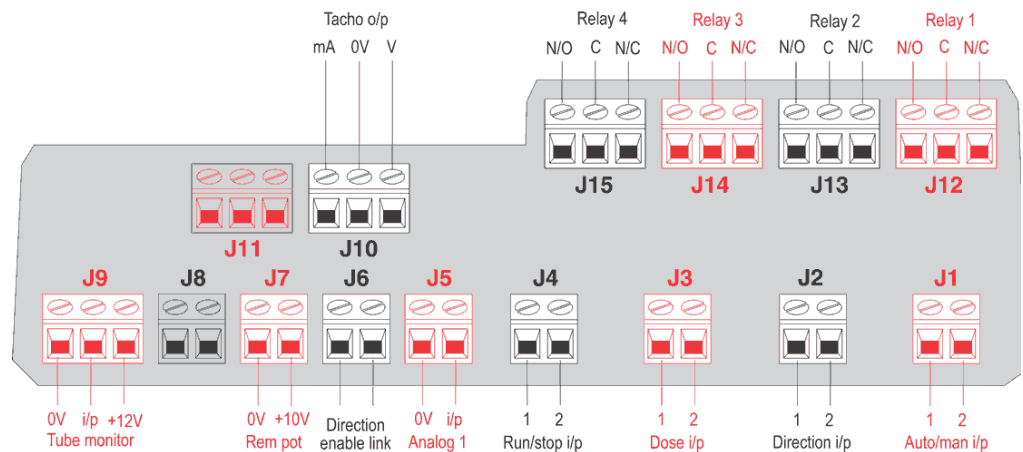

Never apply mains power above 130VAC to the terminals within the 520N SCADA module. Apply the correct signals to the terminals shown below. Limit signals to the maximum values shown. Do not apply voltage across other terminals. Permanent damage, not covered by warranty, may result. The maximum load on the relay contacts of this pump is 1250VA.

19.3 Speed: analogue input

It is possible to control the speed of the pump remotely by one of these methods: a voltage analogue signal within the ranges 0-10V or 1-5V; or a current analogue signal within the range 4-20mA; or a remote potentiometer using the **10V** supply at J7.

The analogue process signal must be applied to the **i/p** terminal of the Analogue 1 connector (J5). Ground to the **0V** terminal of the same connector. The pump will provide an increasing flow rate for a rising control signal (non-inverted response) or an increasing flow rate for a falling control signal (inverted response). See 16.2 Analogue.

4-20mA circuit impedance: 250Ω.

For voltage modes, a stable, reliable voltage source can be used with a DC voltmeter. Circuit impedance: 22kΩ.

Inverting the response is set up in software. Do not invert the polarity of the terminals.

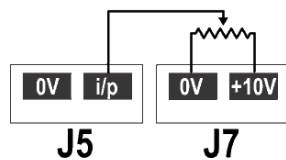

A remote potentiometer with a nominal value of between 1k and 2k with a minimum of 0.25W should be wired between the terminals of the Rem-pot connector (J7) and the **i/p** terminal of the Analogue 1 connector (J5).

When using a remote potentiometer, do not apply a voltage or current control input signal at the same time. The speed control signal will require calibration relative to the minimum and maximum settings of the potentiometer. This is done in software. See 16.1 Trim in the Setup section.

When using a remote potentiometer, it is important to set the analogue input to voltage in the Setup menu. Otherwise the reference voltage supply from the Rem-pot connector will be overloaded and will not provide a full 5V or 10V.

Analogue 1

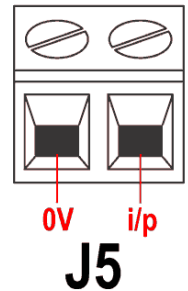

Rem-pot

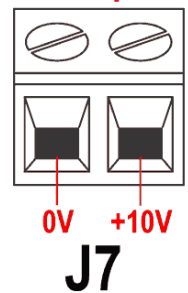

19.4 Speed: analogue output

An analogue voltage output signal is available on the Tacho output connector (J10), between the **V** terminal and the **0V** terminal. The voltage is directly proportional to the pump-head rotation speed. 0V = zero speed; 10V = maximum allowed speed.

There is no mA output on this terminal for the 720US. This is available on the 720DuS.

Tacho o/p

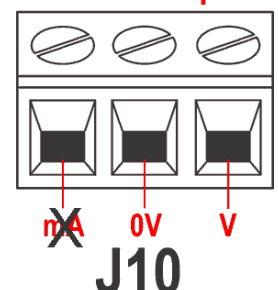

Important: general instructions for remote control inputs

All remote control inputs can be wired in two ways:

Logic

A logic voltage between 80VAC and 130VAC may be wired to the input. The pump is configured to operate without modification anywhere in this range. Each of the four logic inputs is opto-isolated. Terminal 1 is the common or return. Terminal 2 is the signal. Logic low is equivalent to no voltage and logic high to 80-130VAC. Polarity is not important. It is possible to common all the inputs - J1, J2, J3 and J4, terminals 1 OR terminals 2 - to the same 0V line.

Switch

A remote switch may be connected between the input and any voltage supply between 80VAC and 130VAC. Polarity is not important.

19.5 Run/stop input

Remote run / stop: apply a signal of 80VAC to 130VAC across the terminals of the Run/stop input connector (J4). Polarity is not important. See 14.10 Manual operation and remote digital inputs and outputs. To change or set the sense of the run / stop input, see 16.5 Remote stop in the Setup menu.

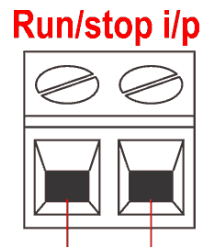

J4

19.6 Direction input

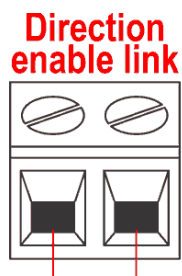

J6

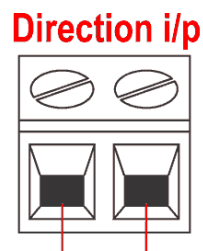

J2

To enable remote direction control and disable the **DIRECTION** key on the keypad, link the terminals of the Direction enable link connector (J6). **Important: Apply no voltage whatever to the Direction enable link (J6).** Apply a signal of 80VAC to 130VAC across the terminals of the Direction input connector (J2) for counter-clockwise rotation. Polarity is not important. With no signal, the pump will rotate clockwise.

19.7 Auto / manual toggle input

Apply a signal of 80VAC to 130VAC across the terminals of the Auto-man input connector (J1) for analogue control. With no signal, the pump is subject to manual control. Polarity is not important.

Auto-man i/p

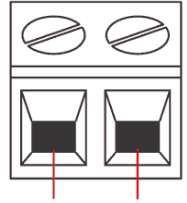

J1

19.8 MemoDose input

Dose i/p

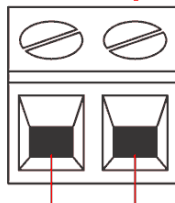

J3

Apply a momentary signal of 80VAC to 130VAC across the terminals of the Dose input connector (J3) to trigger a dose. Polarity is not important. **Note:** This input is software-debounced, so the signal can be either momentary or maintained during the dose. If maintained, the signal must be removed before the next dose.

19.9 Leak detection input

Connect a remote leak-detection device between the **+12V** terminal and the **i/p** terminal on the Tube monitor connector (J9). Closed circuit indicates a leak. Alternatively a logic input may be applied to the **i/p** terminal, ground to the **0V** terminal. High input indicates a leak. Connect the cable of a Watson-Marlow Tube monitor leak detector as follows:

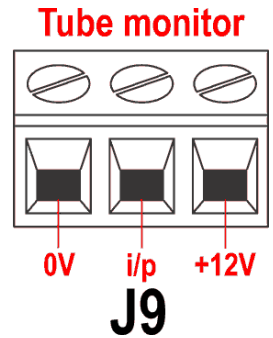

Tube monitor wire colour	720N module
Blue	J9 0V terminal
Yellow	J9 i/p terminal
Red	J9 +12V terminal
Terminate the screen in the 720N module with a 360° EMC gland if required. See 19.2 Wiring up.	

Note: Use only Watson-Marlow 720 series leak detectors.

Important: pump status outputs

Outputs 1-4 are available as single-pole change-over relay contacts: Relay 1, 2, 3 and 4. Connect to the normally open or normally closed contacts of the relay as required and configure the pump's software accordingly. See 16.4 Outputs.

Note: The maximum load on the relay contacts of this pump is 1250VA. Voltages do not require transformer isolation. The relays are specified to switch 115VAC mains-powered loads. The relay outputs are not recommended for 5VDC logic signals. .

19.10 Outputs 1, 2, 3, 4

Note: Relay 1 (J12) is represented here. Relay 2, Relay 3 and Relay 4 (J13, J14 and J15) function identically.

Connect your output device to the **c** (common) terminal of your chosen relay connector and either the **n/c** terminal or the **n/o** terminal (normally closed or normally open) as required. Configure the pump's software accordingly. See 16.4 Outputs.

By default, Relay 1 is configured to indicate Run/Stop status; Relay 2 is configured to indicate Direction status; Relay 3 is configured to indicate Auto/man status; Relay 4 is configured to indicate General alarm status. See 12 Switching the pump on for the first time.

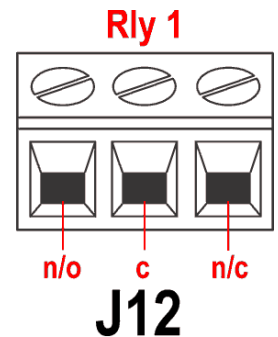

20 Automatic control and operation

Check that the pump is ready to run before selecting automatic operation. Remote control signals may start the pump without warning.

How to get into auto operation

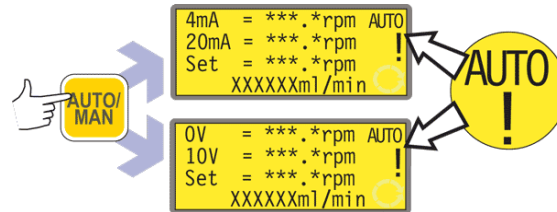

- Press the **AUTO/MAN** key to select automatic operation, or apply a high signal (5V to 24V) to the remote auto/manual input
- The pump responds to the analogue signal as soon as this is done and shows the "AUTO" icon. In this mode the pump is automatically switched into auto-restart mode and displays the ! icon. The only keys active are **STOP**, **AUTO/MAN** and **DIRECTION**.
- If the remote direction input is active and the direction-enable link is applied, the **DIRECTION** key is disabled. If keypad lock is set, only **STOP** is active.
- The pump displays whichever of two auto running screens is appropriate according to the previously selected auto mode - 4-20mA or 0-10V.
- The auto running screens display four pieces of information: the speed at which the pump will rotate after receiving a low signal (4mA or 0V); the speed at which the pump will rotate after receiving a high signal (20mA or 10V); the set speed (that is: the speed at which the pump is currently rotating according to the analogue speed signal); and the flowrate in millilitres per minute.
- The pump also responds to remote digital inputs. If the run/stop input stops the pump, the bottom line of the auto running screen shows "Remote stop". When it starts the pump again, this will disappear and the pump returns to normal running mode.
- Direction can be changed remotely in this mode.
- If the pump is stopped because a leak is detected, the screen displays "LEAK DETECTED. Check and reset, then press Stop". See 21.1 Error codes.
- The remote status outputs operate fully in this mode.

How to get out of auto operation

- Press the **AUTO/MAN** key or make the remote auto / manual input go low (0V). The pump returns to manual operation and retains the set speed and run status from its previous operation in analogue mode.

Emergency stop

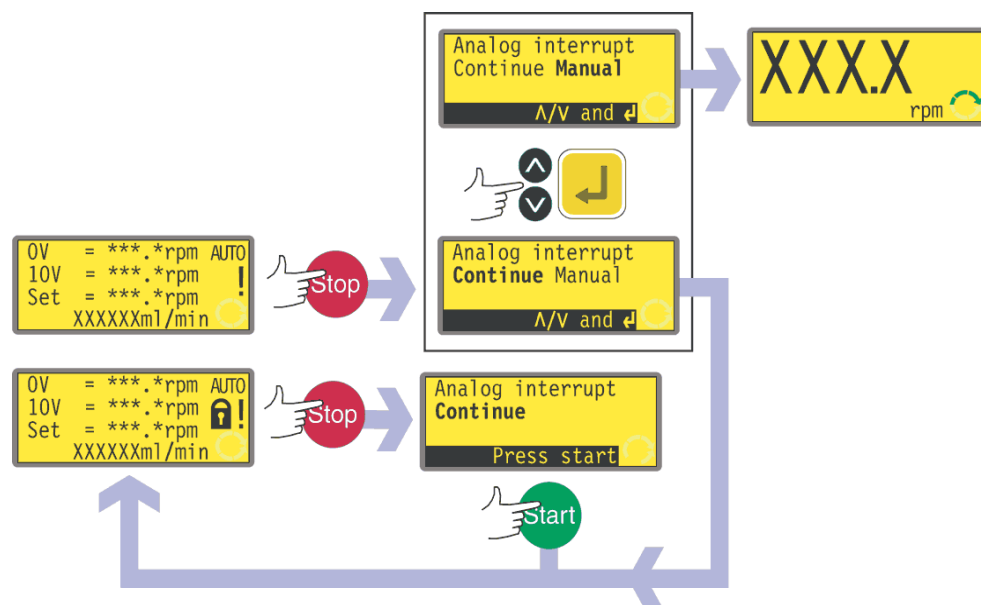

- In an emergency press the **STOP** key. The pump stops and displays an interruption screen.
- If keypad lock is in place when **STOP** is pressed, or if the pump is in auto mode via the digital input, the interruption screen offers one key-press: press **START** to continue auto operation.
- If keypad lock was not in place when **STOP** was pressed, the interruption screen offers a choice: **Continue** to continue auto operation, or **Manual** to switch to manual mode. Use the **UP** and **DOWN** keys to choose and press **ENTER** to confirm.

21 Troubleshooting

If the pump display remains blank when the pump is on, make the following checks:

- Check the position of the voltage selector switch at the rear of the pump.
- Check the mains power switch at the rear of the pump.
- Check that mains power is available to the pump.
- Check the fuse in the fuseholder in the centre of the switchplate at the rear of the pump.
- Check the fuse in the mains power plug if one is present.

If the pump runs but there is little or no flow, make the following checks:

- Check that the tube and rotor are in the pumphead.
- Check that fluid is supplied to the pump.
- Check that the tube is not split or burst.
- Check for any kinks or blockages in the lines.
- Check that any valves in the lines are open.
- Check that the correct wall-thickness tube is being used.
- Check direction of rotation.
- Check that the rotor is not slipping on the drive shaft.

If trouble persists, technical assistance for this product is available from your distributor, or Watson-Marlow Ltd, Falmouth TR11 4RU, United Kingdom.

21.1 Error codes

If an internal error occurs, a flashing error screen is displayed. **Note: Signal out of range, Over signal, No signal and Leak detected** error screens report the nature of an external signal. They do not flash.

Error condition	Suggested action
RAM write error	Attempt to reset by switching power OFF / ON. Or seek support
RAM corruption	Attempt to reset by switching power OFF / ON. Or seek support
OTP ROM error / corruption	Attempt to reset by switching power OFF / ON. Or seek support
OTP ROM read error	Attempt to reset by switching power OFF / ON. Or seek support
Unknown pump type	Check the interface card and cables. Attempt to reset by switching power OFF / ON. Or seek support
Display failure	Seek support
Wrong key-press	Attempt key-press again. Attempt to reset by switching OFF / ON
Motor stalled	Stop pump immediately. Check pumphead and tube. Power OFF/ON may reset. Or seek support
Tacho fault	Stop pump immediately. Power OFF/ON may reset. Or seek support
Speed error	Stop pump immediately. Power OFF/ON may reset. Or seek support
Over current	Stop pump immediately. Check system. Power OFF/ON may reset. Or seek support
Over voltage	Stop pump immediately. Check mains voltage selector switch. Check supply. Power OFF/ON may reset. Or seek support
Under voltage	Stop pump immediately. Check mains voltage selector switch. Check supply. ON/OFF may reset. Or seek support
Watchdog error	Attempt to reset by switching power OFF / ON. Or seek support
Over temperature	Stop pump immediately. Turn OFF. Seek support
Signal out of range	Check analogue control signal range. Trim signal as required. Or seek support
Over signal	Reduce the analogue control signal
No signal	Connect analogue control signal or return to manual control
Leak detected. Check and reset	Remove the cause of any leak. The STOP key resets
Unrecognised key-press	Attempt key-press again. Attempt to reset by switching power OFF/ON. Or seek support
Work overload	Turn OFF. Check power supply. Check pumphead and tubing. Wait 30 minutes. Power ON may reset. Or seek support
Network not detected	Turn OFF. Check network and connections. Or seek support
RS485/RS232 fault	Turn OFF. Check network and connections. Or seek support
RS485/RS232 lost	Turn OFF. Check network and connections. Or seek support
General error condition	Turn OFF. Seek support

22 Drive maintenance

There are no user serviceable parts inside the pump. The unit should be returned to Watson-Marlow or its appointed agents or distributors for service.

23 Drive spares

Replaceable main fuse, type T5A H 250V	FS0043
Foot	MR3002M
Coupling half	CN0090
Coupling spider	CN0088

24 720R, 720RX, 720RE, 720REX, pumphead installation

The 720 pumphead's method of connection to the 720 drive is different from the 701's. The two pumpheads are not interchangeable.

24.1 Pumphead do's and do not's

A correctly engineered installation will promote the best possible tube life, so please ensure that the following guidelines are followed:

Do site the fluid reservoir above the pump wherever possible.

Do keep delivery and suction lines as short and direct as possible.

Do use suction and delivery pipelines with a bore equal to or larger than the bore of the tube fitted in the pumphead. When pumping viscous fluids, the losses caused by increased friction can be overcome by using pipe runs with a cross sectional area several times greater than the pumping element.

Do fit an over-length pump tube in the system to allow its position to be varied relative to the rotor. This will extend tube life and minimise the downtime of the pumping circuit.

Do ensure that connecting pipe work and fittings are suitably rated to handle the predicted pipeline pressure.

If rigid pipe work comes in close proximity to the pumphead, **do** install a drop out section of pipe work to simplify tube replacement.

Do keep the pumphead rollers and track clean and free of grease.

If unsure of an installation please **contact** your local Watson-Marlow Technical Support Office for further assistance.

24.2 720R, 720RX, 720RE, 720REX key safety information



Before opening the pumphead track please ensure that the following safety directions are followed.

- Ensure that the pump is isolated from mains voltage.
- Ensure that there is no pressure in the pipeline.
- If a tube failure has occurred, ensure that any product in the pumphead has been allowed to drain through the controlled waste to a suitable drain.
- Ensure that protective clothing and eye protection are worn if hazardous products are being pumped.

24.3 720R, 720RX, 720RE, 720REX safe-guarding

- Primary safety on 720 series pumps is provided by the tool-lockable pumphead track. Secondary (backup) protection is provided in the form of an electrical guard switch which stops the pump if the pumphead track is opened. The electrical track switch on cased pumps should never be used as primary protection. **Always disconnect the mains power supply to the pump before opening the pumphead track.**

24.4 All 720R and 720RE pumping conditions

- All pressure values in this operating instruction, from which performance and life figures have been calculated, relate to peak pipeline pressures.
- Although rated to 2 bar peak pressure, this pump will generate in excess of 2 bar peak pressure if pipeline restrictions are in place. In instances where it is critical that a peak pressure of 2 bar is not exceeded, pressure relief valves should be installed in the pipeline.
- Ensure that there is always a minimum of one metre of smooth bore flexible tubing connected to the discharge port of the pumphead. This will help minimise any impulse losses and pulsation in the pipeline. This is especially important with viscous fluids and rigid pipework.

24.5 All 720R and 720RE pumpheads: fluid management

The foot assembly has a location available for a float switch leak detector to be fitted. It has an M25 blanking plug on both sides of the foot. One or both can be removed using a 10mm A/F Allen key to facilitate draining. It has an M12 blanking plug on the outer face of the foot, which can be used as a drain if a leak detector is fitted, to allow the fluid level to trigger the switch.

25 Pumphead fitting

25.1 Removing and refitting the pumphead

The procedure for removing and refitting the pumphead is the same for 720R and 720RE pumps.

Removing the pumphead

- From the pumphead remove:
 - the track securing bolt and the track
 - the M8 x 157mm socket head cap screws from the bottom left and bottom right of the pumphead front plate
 - the M8 x 16mm socket head cap screws from the top left and top right of the pumphead back plate
- Pull the pumphead away from the pump drive. The coupling halves will separate, leaving the coupling spider attached to one of the coupling halves. This can easily be removed by hand for cleaning or renewal.



Refitting the pumphead

- Reposition the coupling spider on the drive-side coupling half.
- Hand-rotate the pumphead coupling half until its rotary position aligns with the rotary position of the drive coupling half.
- Align the pumphead and the drive so that the two coupling halves will mesh when pushed together. (If the pumphead foot is in place, the pumphead will be correctly positioned vertically; if the pumphead is visually centred on the drive's mounting plate, the pumphead will be correctly positioned horizontally.)
- Push the pumphead and the drive together. The pumphead is correctly positioned when no gap is visible between the pumphead back plate and the drive mounting plate.
- Apply thread-locking compound to the M8 x 157mm socket head cap screws and reposition them at the bottom left and bottom right; repeat with the M8 x 16mm socket head cap screws at the top left and top right. Tighten all four in sequence.
- Reposition the track and the track securing bolt.

25.2 Removing and refitting an extension pumphead

The procedure for removing and refitting an extension pumphead is the same for 720R and 720RE first pumpheads.

Removing the extension pumphead

- From the extension pumphead remove:
 - the track securing bolt and both tracks
 - the M8 x 307mm socket head cap screws from the bottom left and bottom right of the extension pumphead
 - the M8 x 16mm socket head cap screw from the top right corner of the extension pumphead's back plate.
- Pull the extension pumphead away from the first pumphead.



Refitting the extension pumphead

- Regrease the drive shaft dog of the extension pumphead with the grease supplied. Apply thread locking compound to the M8 x 16mm socket head cap screw in the top corner of the backplate of the extension pumphead.



- Align the drive shaft dog of the extension pumphead with the slot in the drive shaft of the first pumphead. Fit the extension pumphead to the first pumphead. Ensure the backplate of the extension pumphead is flat against the frontplate of the first pumphead. Lightly tighten the socket head cap screw in the top corner of the extension pumphead backplate with the 6mm Allen key provided.
- Apply thread-locking compound to the double-length (M8 x 307mm) socket head cap screws supplied, position them in the bottom corners of the extension pumphead frontplate, and tighten them in sequence with the M8 cap screw in the top corner of the backplate.
- Reposition the track on the first pumphead. Reposition the extension pumphead track on the extension pumphead. Position the track securing bolt.



Note: When a second pumphead is fitted the maximum pressure for each channel should not exceed 1 bar (14.5 psi).

26 Tube loading

720 pumps can be operated with a 720R continuous tubing pumphead or with a 720RE pumphead fitted with Watson-Marlow LoadSure tube elements. For both pumphead types, extension "X" pumphead options are available.

26.1 720R and 720RX continuous tube loading



- Loosen the track compression spring knobs using a 10mm A/F spanner, turning them anticlockwise six (6) times.
- Unscrew the track securing bolt and withdraw the bolt fully. Lift the track by its handle and slide out from under the springs.
- Release the tube clamps by pulling on the release levers and lift out both clamps.
- Lay the tubing across the pumphead. Secure the suction side by sliding in the first tube clamp.
- Fit the delivery clamp loosely to allow any excess tubing to work its way through the pumphead. (See Re-tensioning the tubing, below).



- Slip the right hand end of the track under the springs and position the left hand end so the track securing bolt can be inserted.
- Tighten the track securing bolt with the 6mm Allen key provided.
- Tighten both the track compression spring knobs to a torque of 3Nm (2.2 lb-ft) using a 10mm A/F spanner.

Note: When a second pumphead is fitted the maximum pressure for each channel should not exceed 1 bar (14.5 psi).

Re-tensioning the tubing

Start the pump, allowing any excess tubing to work through the pumphead, then press down the delivery end clamp firmly. Check the tube for movement when the pump is running. If tubing moves through the pumphead, the tube should be more firmly clamped at the suction end. The delivery end should be unclamped to release any excess tubing, pulled tight and then firmly re-clamped again. Repeat as necessary.

When using Marprene continuous tubing, after the first 30 minutes of running, re-tension the tube in the pumphead by releasing the tube clamp on the delivery side a little and pulling the tube tight. This is necessary to counteract the normal stretching that occurs with Marprene which can go unnoticed and result in poor tube life.



26.2 720RE and 720REX LoadSure tube element loading

720 series LoadSure tube elements: remove the chance of premature tube failure caused by incorrect tube loading; avoid over-clamping of tubing; remove the need to re-tension the tubing; extend tube life; reduce maintenance time for tube changeover and cleaning; offer standard industrial tube connections.



- Loosen the track-compression spring knobs using a 10mm A/F spanner, turning them anticlockwise six (6) times.
- Unscrew the track-securing bolt and withdraw the bolt fully. Lift the track by its handle and slide it out from under the springs.
- Locate the D-shaped flange fitted to the end of the tube element into the delivery (right-hand) sliding tube clamp. (The D flange ensures that the element can only be loaded correctly.)



- Slip the right-hand end of the track under the springs.
- Locate the second D-shaped flange into the suction (left-hand) sliding tube clamp. (Lifting the sliding tube clamp will aid the tube-loading.)
- Position the left-hand end of the track so that the track-securing bolt can be inserted.



- Tighten the track-securing bolt with the 6mm Allen key provided.
- Tighten both the track-compression spring knobs to a torque of 3Nm (2.2 lb-ft) using a 10mm A/F spanner.
- Connect both ends of the element to the rest of the system using industrial-standard cam and groove connectors.

27 Pumphead spares: continuous tubing models 720R, 720RX

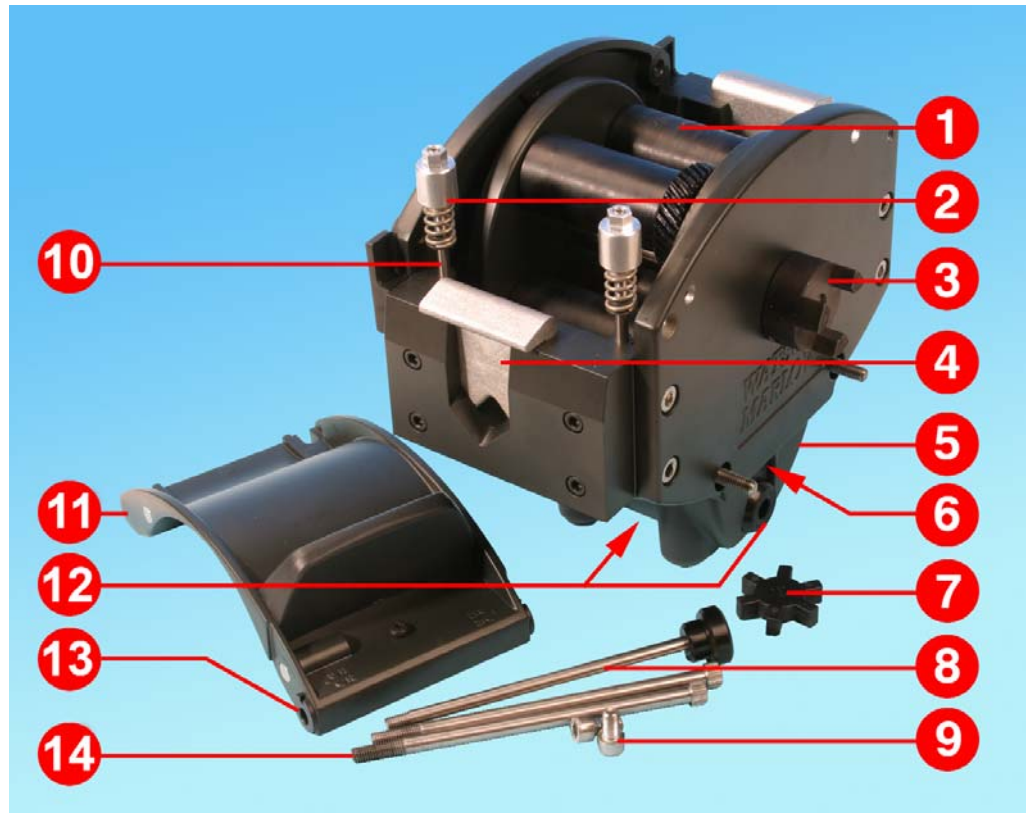

Number	Spare	Description
1	MRA3062A	Rotor assembly ~ 720R
1	MRA0036A	Rotor assembly ~ 720RX
2	MRA0104A	Knob assembly ~ 4.8mm wall tubing
3	CN0090	Coupling half
4	MR0880C	Tube clamp
5	MRA3061A	Foot assembly
6	CN0229	M12 blanking plug
7	CN0088	Coupling spider
8	MRA0027A	Pivot pin assembly
8	MRA0034A	Pivot pin assembly ~720RX
9	FN0611	M8 x 16mm screw
10	MR662T	Stud ~ Set to 61mm
11	MRA3063A	Track assembly
12	CN0228	M25 blanking plug
13	MR0882M	Eccentric bush
14	MR3041T	M8 x 307mm bolt ~ 720RX
14	MR3040T	M8 x 157mm bolt ~ 720R

28 Pumphead spares: LoadSure element models 720RE, 720REX

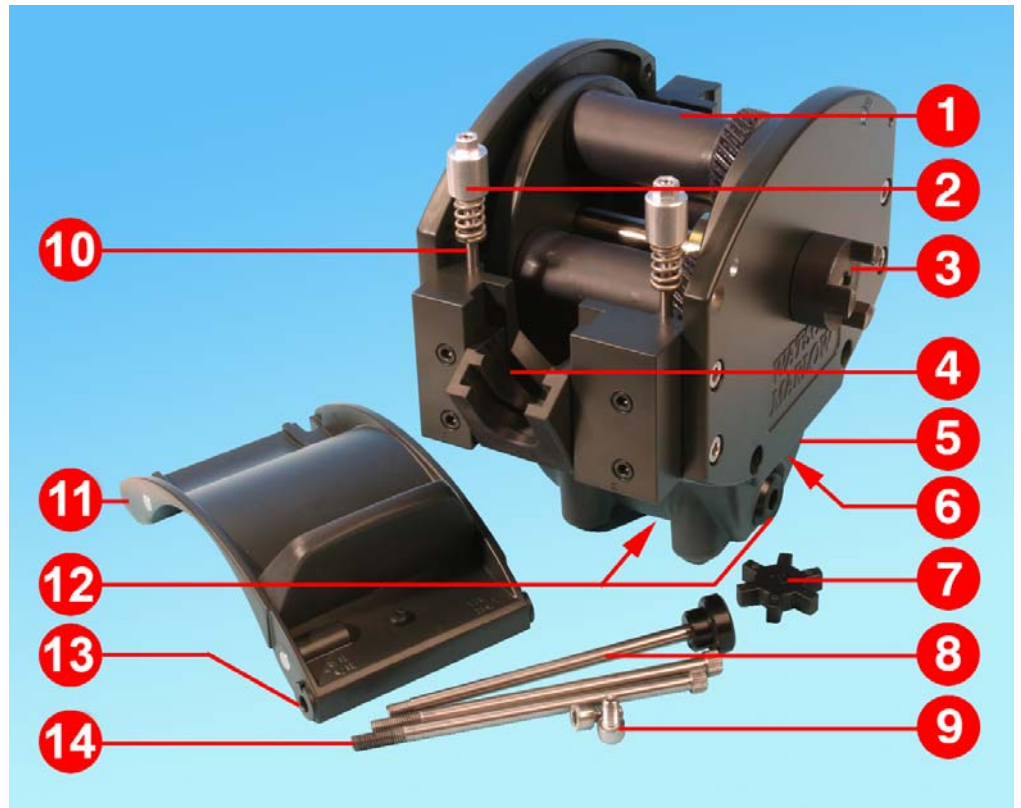

Number	Spare	Description
1	MRA3062A	Rotor assembly ~ 720RE
1	MRA0036A	Rotor assembly ~ 720REX
2	MRA0319A	Knob assembly ~ 4.8mm wall tubing
3	CN0090	Coupling half
4	MR1118T	Sliding clamp
5	MRA3061A	Foot assembly
6	CN0229	M12 blanking plug
7	CN0088	Coupling spider
8	MRA0027A	Pivot pin assembly
8	MRA0034A	Pivot pin assembly ~720RX
9	FN0611	M8 x 16mm screw
10	MR662T	Stud ~ Set to 61mm
11	MRA3064A	Track assembly
12	CN0228	M25 blanking plug
13	MR0882M	Eccentric bush
14	MR3041T	M8 x 307mm bolt ~ 720REX
14	MR3040T	M8 x 157mm bolt ~ 720RE

29 Pumphead spares: rotor



Number	Spare	Description
1	MR0879A	Rotor flange
2	MR0667T	Spacer
3	FN0420	Screw M5x16 socket countersunk
4	MRA0039A	Shaft with sun gear ~720R
5	MR0773B	Drive slot plug
6	MRA0020A	Roller assembly
7	FN0722	Washer
8	BB0018	15mm bearing



30 720R and 720RE flow rates

Flow rates were obtained using silicone tubing with the pumphead rotating clockwise, pumping water at 20C with zero suction and delivery pressures. For critical applications determine flow rates under operating conditions.

Flow rates, 720R and 720RE, 360 rpm						
bore	mm	9.6 (720R)	12.7	15.9	19	25.4
	in	³ / ₈ (720R)	¹ / ₂	⁵ / ₈	³ / ₄	1
#		193 (720R)	88	189	191	92
litre/hour		420	780	1100	1500	2000
USGPM		1.9	3.4	4.8	6.6	8.8

Note: these figures refer to the performance of a single pumphead; where twin pumpheads are used, the figures should be doubled.

31 LoadSure tube element product codes (720RE)

Sanitary elements with PVDF Tri-clamp style connectors *						
						
mm	inch	#	STA-PURE	Bioprene TL	Pumpsil silicone	
12.7	¹ / ₂	88	960.0127.PFT	903.0127.PFT	913.A127.PFT	
15.9	⁵ / ₈	189	960.0159.PFT	903.0159.PFT	913.A159.PFT	
19.0	³ / ₄	191	960.0190.PFT	903.0190.PFT	913.A190.PFT	
25.4	1	92	960.0254.PFT	903.0254.PFT	913.A254.PFT	
Industrial elements with PP Cam-and-Groove connectors †						
			Marprene TL	Neoprene	Pumpsil silicone	
12.7	¹ / ₂	88	902.0127.PPC	920.0127.PPC	913.A127.PPC	
15.9	⁵ / ₈	189	902.0159.PPC	920.0159.PPC	913.A159.PPC	
19.0	³ / ₄	191	902.0190.PPC	920.0190.PPC	913.A190.PPC	
25.4	1	92	902.0254.PPC	920.0254.PPC	913.A254.PPC	

* 12.7mm, 15.9mm and 19.0mm elements have ³/₄in Tri-clamp style connectors. 25.4mm elements have 1in Tri-clamp style connectors.

† 12.7mm, 15.9mm and 19.0mm elements have ³/₄in Cam-and-Groove connectors. 25.4mm elements have 1in Cam-and-Groove connectors.

32 Continuous tubing product codes (720R)

mm	inch	#	Marprene	Bioprene	Pumpsil silicone
9.6	3/8	193	902.0096.048	903.0096.048	913.A096.048
12.7	1/2	88	902.0127.048	903.0127.048	913.A127.048
15.9	5/8	189	902.0159.048	903.0159.048	913.A159.048
19.0	3/4	191	902.0190.048	903.0190.048	913.A190.048
25.4	1	92	902.0254.048	903.0254.048	913.A254.048
			Neoprene	STA-PURE	Fluorel
9.6	3/8	193	920.0096.048	960.0096.048	
12.7	1/2	88	920.0127.048	960.0127.048	
15.9	5/8	189	920.0159.048	960.0159.048	
19.0	3/4	191	920.0190.048	960.0190.048	970.A190.048
25.4	1	92	920.0254.048	960.0254.048	

33 Trademarks

Watson-Marlow, Bioprene, Pumpsil and Marprene are trademarks of Watson-Marlow Limited.

Fluorel is a trademark of 3M.

Sta-Pure and Chem-Sure are trademarks of W.L.Gore and Associates.

34 Warning not to use pumps in patient-connected applications

Warning: These products are not designed for use in, and should not be used for patient-connected applications.

35 Publication history

m-720us-4x-us-01.qxp: Watson-Marlow 720US.

First published 07 07.

36 Decontamination certificate

In compliance with the UK Health and Safety at Work Act and the Control of Substances Hazardous to Health Regulations, you are required to declare the substances which have been in contact with product(s) you return to Watson-Marlow or its subsidiaries or distributors. Failure to do so will cause delays. Please ensure that you fax us this form and receive an RGA (Returned Goods Authorisation) before you despatch the product(s). A copy of this form must be attached to the outside of the packaging containing the product(s). Please complete a separate decontamination certificate for each product. You are responsible for cleaning and decontaminating the product(s) before return.

Your name	<input type="text"/>	Company	<input type="text"/>
Address	<input type="text"/>		
Postcode/zip	<input type="text"/>	Country	<input type="text"/>
Telephone	<input type="text"/>	Fax	<input type="text"/>
Product type	<input type="text"/>	Serial number	<input type="text"/>
To speed the repair, please describe all known faults	<input type="text"/>		
The product has ...	<input type="checkbox"/> Been used <input type="checkbox"/> Not been used		
	<i>If the product has been used, please complete all the following sections. If the product has not been used, please just sign this form.</i>		
Names of chemicals handled with product(s)	<input type="text"/>		
Precautions to be taken in handling these chemicals	<input type="text"/>		
Action to be taken in the event of human contact	<input type="text"/>		
	<i>I understand that the personal data collected will be kept confidentially in accordance with the UK Data Protection Act 1998.</i>		
Signature	<input type="text"/>	RGA number	<input type="text"/>
		Your position	<input type="text"/>
		Date	<input type="text"/>
	<i>Please print out, sign and fax to Watson-Marlow Pumps at +44 1326 376009.</i>		