

## CD-ROM

The CD-ROM, which is inserted in the cover, contains the user manual of the SPX40, SPX50, SPX65, SPX80 and SPX100 hose pumps. The CD-ROM also contains a replacement instruction for the pump hose. This replacement instruction is only for users that are familiar with the replacement procedures in the user manual.

### System requirements

The program on CD-ROM requires a PC with the following minimum system requirements:

- Pentium I 100 MHz
- 64 MB internal memory
- 256 colors

The following software must be installed on the PC:

- Adobe Acrobat Reader
- Internet Explorer

### How to use the CD-ROM

- 1 Put the CD-ROM in the CD drive.
- 2 Close the CD drive.  
The CD-ROM will start automatically.
- 3 Wait until the various language versions appear on screen.
- 4 Select the required language (click 1x with the left mouse button).  
The program Adobe Acrobat Reader will automatically start and the required user manual appears on screen.

### Shortcuts

In the left margin you will find the various chapters and paragraphs. These can be accessed directly by clicking on the required chapter or paragraph.

In the text you will find hyperlinks to chapters or paragraphs. These hyperlinks are linked with the required chapters or paragraphs. By clicking a shortcut the required chapter or paragraph appears on screen.



# Hose pump series SPX40, SPX50, SPX65, SPX80 and SPX100

## Manual

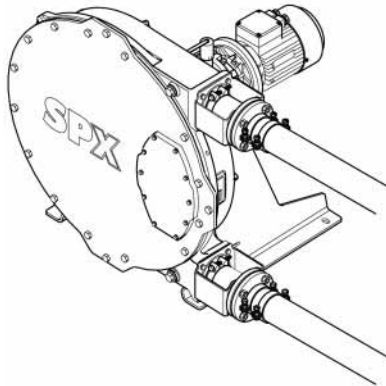

---

© 2010 Watson-Marlow Bredel B.V.

All rights reserved.

The information provided herein may not be reproduced and/or published in any form, by print, photoprint, microfilm or any other means whatsoever (electronically or mechanically) without the prior written authorization of Watson-Marlow Bredel B.V.

Information within this manual is subject to change without notice. Neither Watson-Marlow Bredel B.V. nor any other representatives will be liable for damages arising out of or in connection with the use of this manual. This is a comprehensive limitation of liability that applies to all damages of any kind, including (without limitation) compensatory, direct, indirect or consequential damages, loss of data, income or profit, loss of or damage to property and claims of third parties

Watson-Marlow Bredel B.V. is providing this manual and its contents on an "as is" basis and makes no representations or warranties of any kind with respect to this manual or its contents. Watson-Marlow Bredel B.V. disclaims all such representations and warranties. In addition Watson-Marlow Bredel B.V. does not represent or warrant that the information accessible via this manual is accurate, complete or current.

Names, trade names, brands, etc. used by Watson-Marlow Bredel B.V. may not, as per the legislation concerning the protection of trade names, be considered as available.

---

## CONTENTS

### 1 GENERAL

1.1	<i>How to use this manual</i> .....	8
1.2	<i>Original instructions</i> .....	8
1.3	<i>Other supplied documentation</i> .....	8
1.4	<i>Service and support</i> .....	8
1.5	<i>Used products and the environment</i> .....	9

### 2 SAFETY

2.1	<i>Pictograms</i> .....	10
2.2	<i>Intended use</i> .....	10
2.3	<i>Use in potentially explosive atmospheres</i> .....	11
2.4	<i>Responsibility</i> .....	11
2.5	<i>Qualification of the user</i> .....	11
2.6	<i>Regulations and instructions</i> .....	12

### 3 WARRANTIES

### 4 DESCRIPTION

4.1	<i>Identification of the product</i> .....	14
4.1.1	<i>Identification of the product</i> .....	14
4.1.2	<i>Identification of the pump</i> .....	14
4.1.3	<i>Identification of the gearbox</i> .....	14
4.1.4	<i>Identification of the electric motor</i> .....	15
4.1.5	<i>Identification of the pump hose</i> .....	15
4.2	<i>Construction of the pump</i> .....	16
4.3	<i>Operation of the pump</i> .....	16
4.4	<i>Pump hose</i> .....	18
4.4.1	<i>General</i> .....	18
4.4.2	<i>Hose compression force adjustment (shimming)</i> .....	20
4.4.3	<i>Lubrication and cooling</i> .....	20
4.5	<i>Gearbox</i> .....	20
4.6	<i>Electric motor</i> .....	21
4.7	<i>Available options</i> .....	21

---

<b>5</b>	<b>INSTALLATION</b>	
5.1	<i>Unpacking</i> .....	22
5.2	<i>Inspection</i> .....	22
5.3	<i>Installation conditions</i> .....	22
	5.3.1 Ambient conditions .....	22
	5.3.2 Set-up .....	22
	5.3.3 Pipe work .....	23
5.4	<i>Lifting and moving the pump</i> .....	25
5.5	<i>Placing the pump</i> .....	26
<b>6</b>	<b>COMMISSIONING</b>	
6.1	<i>Preparations</i> .....	27
6.2	<i>Commissioning</i> .....	27
<b>7</b>	<b>MAINTENANCE</b>	
7.1	<i>General</i> .....	29
7.2	<i>Maintenance and periodic inspections</i> .....	29
7.3	<i>Cleaning pump hose</i> .....	31
7.4	<i>Changing lubricant</i> .....	31
7.5	<i>Changing oil in gearbox</i> .....	32
7.6	<i>Replacing pump hose</i> .....	33
	7.6.1 Removing pump hose .....	33
	7.6.2 Cleaning the pump head .....	36
	7.6.3 Fitting the pump hose .....	37
7.7	<i>Exchanging replacement parts</i> .....	40
	7.7.1 General .....	40
	7.7.2 Replacing pressing shoes .....	40
	7.7.3 Replacing seal and wear ring .....	42
	7.7.4 Replacing bearings .....	45
7.8	<i>Adjusting hose compression force (shimming)</i> .....	46
7.9	<i>Fitting options</i> .....	49
	7.9.1 Fitting a high-level float switch .....	49
	7.9.2 Fitting a low level float switch .....	50
	7.9.3 Fitting revolution counter .....	52
<b>8</b>	<b>STORAGE</b>	
8.1	<i>Hose pump</i> .....	54
8.2	<i>Pump hose</i> .....	54

**9 TROUBLESHOOTING**

**10 SPECIFICATIONS**

10.1 *Pump head* ..... 60

    10.1.1 Performance ..... 60

    10.1.2 Materials ..... 61

    10.1.3 Surface treatment ..... 62

    10.1.4 Lubricant table pump ..... 62

    10.1.5 Weights ..... 62

    10.1.6 Shims specifications ..... 63

    10.1.7 Torque figures ..... 65

10.2 *Lubricant table gearbox* ..... 67

10.3 *Parts list* ..... 68

    10.3.1 Overview ..... 68

    10.3.2 Cover assembly ..... 69

    10.3.3 Rotor assembly ..... 70

    10.3.4 Pump housing assembly ..... 71

    10.3.5 Support assembly ..... 72

    10.3.6 Flange assembly ..... 73

    10.3.7 Revolution counter assembly ..... 74

    10.3.8 Lubricants ..... 75

**11 SAFETY FORM**

## **1 GENERAL**

### **1.1 How to use this manual**

This manual is intended as a reference book by means of which qualified users are able to install, commission and maintain the hose pumps mentioned on the front cover.

### **1.2 Original instructions**

The original instructions for this manual have been written in English. Other language versions of this manual are a translation of the original instructions.

### **1.3 Other supplied documentation**

Documentation of components such as electric motors, gearboxes, etc. is normally not included in this manual. But if additional documentation is supplied, you must follow the instructions in this additional documentation.

### **1.4 Service and support**

For information with respect to specific adjustments, installation, maintenance or repair jobs which fall beyond the scope of this manual, contact your Watson-Marlow Bredel representative. Make sure you have the following data at hand:

- Serial number hose pump
- Article number pump hose
- Article number gearbox
- Article number electric motor
- Article number frequency controller

You will find these data on the identification plates or stickers of the pump head, the pump hose, the gearbox and the electric motor. Refer to § 4.1.1.

## 1.5 Used products and the environment

**CAUTION**

Always observe the local rules and regulations with respect to processing (non reusable) parts of the hose pump.

Inquire with your local government about the possibilities for reuse or environment friendly processing of packaging materials, (contaminated) lubricant and oil.

## 2 SAFETY

### 2.1 Pictograms

In this manual the following symbols are used:

	<p><b>WARNING</b> Procedures which, if not carried out with the necessary care, may result in serious damage to the hose pump or in serious bodily harm.</p>
----------------------------------------------------------------------------------	------------------------------------------------------------------------------------------------------------------------------------------------------------------

	<p><b>CAUTION</b> Procedures which, if not carried out with the necessary care, may result in serious damage to the hose, the pump, the surrounding area or the environment.</p>
----------------------------------------------------------------------------------	--------------------------------------------------------------------------------------------------------------------------------------------------------------------------------------

	<p>Remarks, suggestions and advice.</p>
----------------------------------------------------------------------------------	-----------------------------------------

	<p><b>WARNING</b> Procedures, remarks, suggestions or advice, which refer to use in potentially explosive atmospheres in accordance with the ATEX Directive 94/9/EC.</p>
----------------------------------------------------------------------------------	------------------------------------------------------------------------------------------------------------------------------------------------------------------------------

### 2.2 Intended use

The hose pump is exclusively designed for pumping suitable products in defined applications.

The manufacturer cannot be held responsible for damage or harm resulting from misapplication or negligence. If you want to change the application of your hose pump from its originally intended service, contact your Watson-Marlow Bredel representative first to confirm suitability.

### 2.3 Use in potentially explosive atmospheres

The *pump head* and *gearbox* mentioned in this manual are suitable for use in a potentially explosive atmosphere. Use in Potentially explosive atmospheres requires special configuration of the pump unit (See 4.7). The pumps mentioned meet the requirements as stated in the European Directive 94/9/EC (ATEX Directive).

The pumps belong to:

- Group II Appliances, category 2 G c k T4

### 2.4 Responsibility

The manufacturer does not accept any responsibility for damage or harm caused by not (strictly) observing the safety regulations and instructions in this manual and the also supplied documentation, or by negligence during installation, use, maintenance and repair of the hose pumps mentioned on the front cover. Depending on the specific working conditions or accessories used, additional safety instructions can be required.

Immediately contact your Watson-Marlow Bredel representative, if you noticed a potential danger while using your hose pump.

**WARNING**

The user of the hose pump is always fully responsible for observing the local valid safety regulations and directives. Observe these safety regulations and directives when using the hose pump.

### 2.5 Qualification of the user

The installation, use and maintenance of the hose pump is only reserved for well trained and qualified users. Temporary staff and persons in training may only use the hose pump under the supervision and responsibility of well trained and qualified users.

---

## 2.6 Regulations and instructions

- Everyone who will work with the hose pump must be familiar with the content of this manual and observe the instructions carefully.
- The user must ensure that this manual, as well as all other documentation relating to pump components, is made readily accessible to anyone who is expected to work with or service the hose pump.

### 3      WARRANTIES

The manufacturer offers a 2-year warranty on proper workmanship of all parts of the hose pump. Exclusion is made for normal wear and tear of consumables, such as pump hoses, lubricant, hose clamps, pressing shoes, ball bearings, wear ring, and seals, or parts which have been misused or damaged through negligence.

This manufacturer's warranty is null and void for any user who has substituted the parts of an alternate manufacturer into a Watson-Marlow Bredel hose pump.

Damaged parts may be returned to the manufacturer for warranty analysis. If failure was determined caused by faulty workmanship, the manufacturer will repair or replace the faulty component.

The parts must be accompanied by a fully completed and signed health and safety form, as present in the back of this manual. The form must be applied to the outside of the shipping carton.

Parts which have been contaminated or which have been corroded by chemicals or other substances, which can pose a health risk, must be cleaned before they are returned to the manufacturer. Furthermore, it should be indicated on the health and safety form, which specific cleaning procedure has been followed, and it should be indicated that the equipment has been decontaminated. The safety form is required at all items, even if the parts have not been used.

Warranties purporting to be on behalf of Watson-Marlow Bredel B.V. made by any person, including representatives of Watson-Marlow Bredel B.V., its subsidiaries, or its distributors, which do not accord with the terms of this warranty shall not be binding upon Watson-Marlow Bredel B.V. unless expressly approved in writing by a Director or Manager of Watson-Marlow Bredel B.V.

## 4 DESCRIPTION

### 4.1 Identification of the product

#### 4.1.1 Identification of the product

The hose pump can be identified based on the identification plates or stickers on:

- A: Pump head
- B: Gearbox
- C: Electric motor
- D: Pump hose

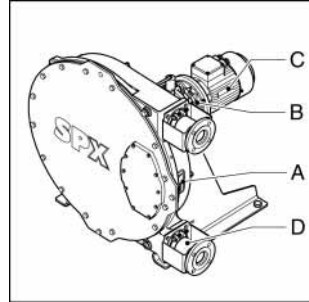

#### 4.1.2 Identification of the pump

The identification plate on the pump head contains the following data:

- A: Pump model
- B: Serial number

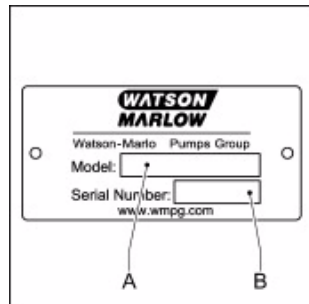

#### 4.1.3 Identification of the gearbox

The identification plate on the gearbox contains the following data:

- A: Serial number (S.N.)
- B: Type number (Type/Output)
- C: Reduction (i=)
- D: Input (adaptation of the motor to the gearbox)
- E: Mechanic code (MC)
- F: Date
- G: Watson-Marlow Bredel article or order number (PN)

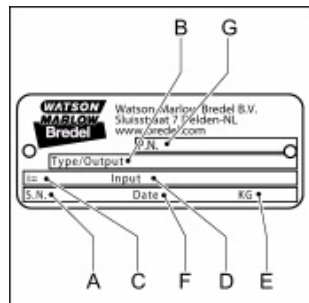

#### 4.1.4 Identification of the electric motor

The identification plate on the electric motor contains the following data:

- A:** Serial number
- B:** Type number
- C:** Power
- D:** Voltage
- E:** Frequency
- F:** Pole no./Speed
- G:** Insulation class
- H:** Rise in temperature
- I:** Watson-Marlow Bredel article or order number

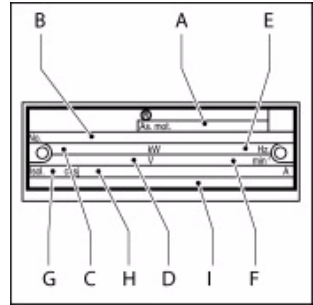

#### 4.1.5 Identification of the pump hose

The identification sticker on the pump hose contains the following data:

- A:** Reorder number
- B:** Internal diameter
- C:** Type of material of inner liner
- D:** Maximum permissible working pressure
- E:** Production code

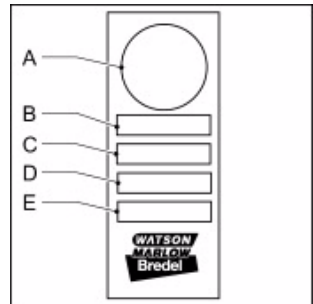

#### 4.2 Construction of the pump

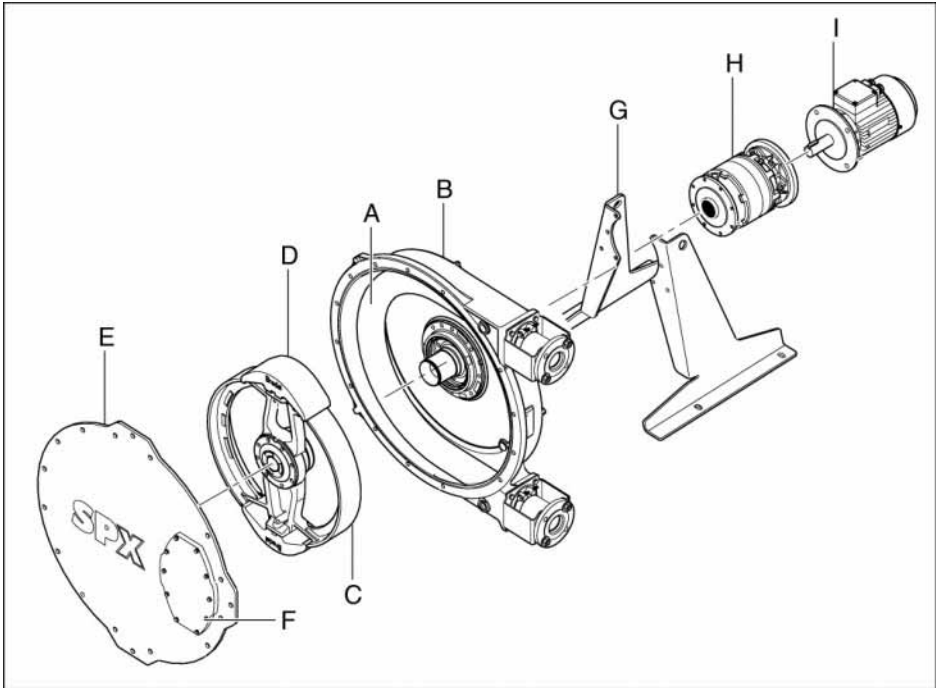

- A: Pump hose
- B: Pump housing
- C: Rotor
- D: Pressing shoes
- E: Cover
- F: Inspection window
- G: Supports
- H: Gearbox
- I: Electric motor

#### 4.3 Operation of the pump

The heart of the pump head consists of a specially constructed pump hose (A), which lies at the inside of the pump housing (B) against the track. Both ends of the hose are connected to the suction and discharge

lines by means of a flange construction (C). A bearing-mounted rotor (D) with two facing pressing shoes (E) is in the center of the pump head.

In phase 1 the lower pressing shoe compresses the pump hose by the rotational movement of the rotor, forcing the fluid through the hose. As soon as the pressing shoe has passed, the hose recovers to its original shape due to the mechanical properties of the material.

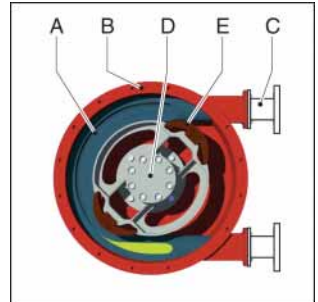

In phase 2 the product is drawn into the hose by the (continuous) turning motion of the rotor.

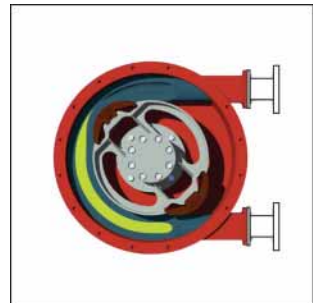

In phase 3, the second pressing shoe will subsequently compress the pump hose. Due to the continuous rotating movement of the rotor not only new product is sucked in, but also the already present product is pressed out by the pressing shoe. When the first pressing shoe runs from the pump hose, the second pressing shoe has already closed the pump hose and the product is prevented from flowing back. This method of liquid displacement is also known as the "positive displacement principle".

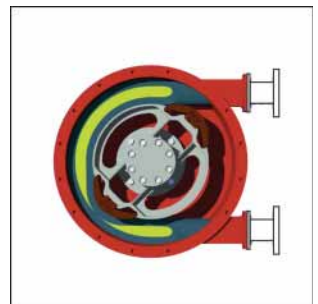

## 4.4 Pump hose

### 4.4.1 General

The pump hose is made of special rubbers, reinforced with nylon cords and is constructed as follows:

- A:** Outer extruded layer made of natural rubber
- B:** Four nylon reinforcement layers
- C:** Inner extruded liner

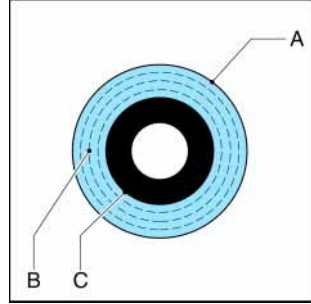

The pump hose liner material should be chemically resistant with the product to be pumped. Dependent on the specific requirements of your application a corresponding pump hose must be selected. For each pump model various hose types are available.

The material of the inner liner of the pump hose determines the hose type. Each hose type is marked by a unique color code.

Hose type	Material	Color code
NR	Natural rubber	Purple
NBR	Buna N	Yellow
EPDM	EPDM	Red
CSM	Hypalon <sup>®</sup>	Blue

#### Natural Rubber\*

Always the first choice hose. A highly dynamic material, which has excellent abrasion resistance and mechanical strength, and is generally resistant to diluted acids and alcohols.

Max. liquid temperature 80 °C (175 °F).

Min. temperature -20 °C (-5 °F).

#### Buna N\*

A highly abrasion proof and wear resistant material that is generally resistant to oils, fats, alkaline, and detergents. Suitable for a wide range of food handling and meets FDA and 3A standards.

Max. liquid temperature 80 °C (175 °F).

Min. temperature -10 °C (15 °F).

**EPDM\***

Good chemical resistance especially to concentrated acids, ketones, and alcohols.

Max. liquid temperature 90 °C (195 °F).

Min. temperature -10 °C (15 °F).

Consult Watson-Marlow Bredel technical services for details on higher temperature operation, up to 90 °C with EPDM.

**Hypalon® \***

Good chemical resistance for strong oxidizing products like concentrated acids and oxygen generating substances.

Max. liquid temperature 80 °C (175 °F).

Min. temperature -10 °C (15 °F)

Consult Watson-Marlow Bredel technical services for RPM limitations when using Hypalon®.



\* Consult your Watson-Marlow Bredel representative for more detailed information about the chemical and temperature resistance of pump hoses.

The Watson-Marlow Bredel pump hoses have been carefully machined, therefore there are minimum tolerances in wall thickness. This is very important to guarantee the correct compression of the pump hose, because:

- When the compression is too high, it creates a too high load of the pump and pump hose, which may result in a reduction of the life of the pump hose and bearings.
- When the compression is too low this will result in high velocity backflow (slip). Backflow results in a reduction of pump performance, hydraulic efficiency, and negatively impact the life of the pump hose.

#### 4.4.2 Hose compression force adjustment (shimming)

In order to achieve optimal life of the pump hose, the compression force of the pump hose can be adjusted by placing a number of shims under the pressing shoes. The shims (A) are fitted between the rotor (B) and the pressing shoe (C). The number of shims will vary for each discharge pressure situation.

The paragraph 7.8 describes how to select and install the shims.

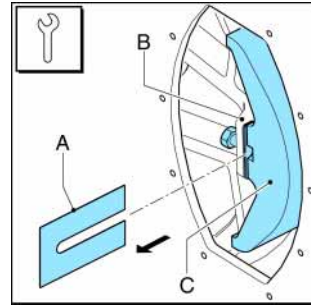

#### 4.4.3 Lubrication and cooling

The pump head, in which the rotor and pump hose can be found, is filled with Watson-Marlow Bredel Genuine Hose Lubricant. This lubricant lubricates the movement between the hose and the pressing shoes and dissipates the generated heat via the pump housing and the cover.

The lubricant is food grade. Refer to § 10.1.4 for the required quantity and NSF registration.

	Consult your Watson-Marlow Bredel representative for lubrication recommendations when operating the hose pump below 2 rpm.
-----------------------------------------------------------------------------------	----------------------------------------------------------------------------------------------------------------------------

#### 4.5 Gearbox

The hose pump types described in this manual use planetary gearbox units. The gearbox units are characterized by their compact and modular construction.

This modular construction enables a wide range of reductions, torques and connection possibilities for the electric motor.

#### 4.6 Electric motor

If the electric motor has been supplied, please consult the motor manual and nameplate for details on its specification. Most typically, AC squirrel cage induction motors drive hose pumps.

#### 4.7 Available options

The following options are available for the hose pump:

- High (lubricant) level float switch
- Low (lubricant) level float switch
- Revolution counter



The high level float switch is mandatory for use in potentially explosive atmospheres. If the pump is to be used in potentially explosive atmospheres, contact your Watson-Marlow Bredel representative.

## 5 INSTALLATION

### 5.1 Unpacking

When unpacking carefully follow the instructions as given on the packaging or on the hose pump.

### 5.2 Inspection

Check that your delivery is correct and check it for any transport damage. Refer to § 4.1.1. Report any damage immediately to your Watson-Marlow Bredel representative.

### 5.3 Installation conditions

#### 5.3.1 Ambient conditions

Make sure that the hose pump is in an area where the ambient temperature during operation is not lower than  $-20\text{ }^{\circ}\text{C}$  ( $-4\text{ }^{\circ}\text{F}$ ) and not higher than  $+45\text{ }^{\circ}\text{C}$  ( $+113\text{ }^{\circ}\text{F}$ ). Note that some motors may not be suitable for this entire range of temperature. Consult your motor manufacturer's documentation for suitability of the motor in your ambient conditions.

#### 5.3.2 Set-up

- The pump materials and protective layers are suitable for indoor set-up and a protected outdoor set-up. Under certain conditions the pump is suitable for limited outdoor set-up or a salty or aggressive atmosphere. Consult your Watson-Marlow Bredel representative for more information.
- Make sure that the floor surface is horizontal and has a maximum slope of 1 mm per meter (0.012" per foot). Bolt the pump down using the mounting points provided.
- Make sure that there is sufficient room around the pump to carry out the necessary maintenance activities.

- Make sure that the room is sufficiently ventilated, so that the heat developed by the pump and drive can be discharged. Keep some distance between the ventilation cover of the electric motor and wall to enable the supply of necessary cooling air.
- A qualified electrician who is fully conversant with the appropriate regulations should connect the electric motor.
- Motor wiring: Follow the guidelines issued by the motor manufacturer. A current overload relay should be fitted to a contact breaker. Connect the motor in accordance with the manufacturer's instructions. When a thermal protection switch is fitted in the motor, the leads will be found in the motor terminal box. They should be connected to stop the pump if the switch changes state.
- A qualified electrician who is fully conversant with the appropriate regulations should connect liquid level switches and/or revolution counter.

### 5.3.3 Pipe work

When determining and connecting suction and discharge lines consider the following points:

- **Do** keep delivery and suction lines as short and direct as possible.
- Keep the piping at a minimum equal to or greater than the bore size of the pump. Increase the bore size of the pipe work when the duty fluid has a high velocity or inertia. This will help keep friction and impulse losses to a minimum. Where critical velocities are a concern consult your Watson-Marlow Bredel representative.
- **Do** limit the presence of sharp bends in the process lines. Make sure that the radius of any bends is as large as possible ( $R=4d$  to  $5d$ ). It is recommended to use Y-connections instead of T-connections.

- Consult your Watson-Marlow Bredel representative for recommendations on mounting pulsation dampening devices. A pulsation dampener and/or inlet pulse accumulator may be necessary if the relative density and pump speed is high and the line lengths are long.
- The self-priming and positive displacement nature of peristaltic pumps means that valves are not required. If for whatever reason, valves are fitted into the system, they must have a straight fluid path and cause minimum restriction to flow in the pumping circuit. Note that check valves directly in the process stream may increase pulsation and negatively impact hose life.
- For ease of hose changing and some pulsation suppression, it is recommended to use a segment of flexible hose between the pump flange and hard piping of the suction and/or discharge line. A segment of three quarters (3/4) of the pump hose length for the flexible pipe work is recommended. Watson-Marlow Bredel also recommends installing an isolation valve and pipe-drain in the suction and discharge pipe work to allow fluid isolation and drainage from the pump during maintenance. Following these recommendations will help minimize process fluid exposure by maintenance personnel.
- For the flexible hoses select compatible materials and ensure the installation is suited for the design pressure of the system.
- Prevent any possibilities of exceeding the maximum working pressure of the hose pump. Refer to § 10.1.1. If necessary install a pressure

relief valve or shutdown switch. Consult your Watson-Marlow Bredel representative for more detailed information.



**CAUTION**

Consider the maximum permissible working pressure on the discharge side. Exceeding the maximum working pressure may lead to serious damage to the pump.

- Make sure that the maximum forces on the flanges are not exceeded. The permissible loads are given in the following table.

Maximum permissible loads on the pump flange					
Force	SPX40	SPX50	SPX65	SPX80	SPX100
F1	1000	1400	1400	2000	2000
	225	315	315	450	450
F2	200	300	300	400	400
	45	67	67	90	90
F3	500	700	700	1000	1000
	112	157	157	225	225

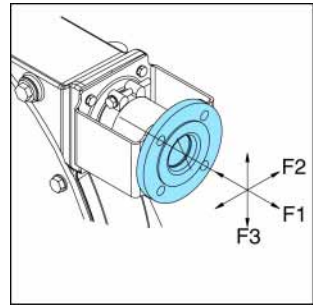

	Newton [N]
	Pounds Force [lbf]

**5.4 Lifting and moving the pump**

For lifting and moving the pump, it has been fitted with a lifting point. This lifting point (A) is fitted on the upper side of the cover. The maximum rating of the lifting point depends on the pump model. Make sure that the total of weight to be moved will not exceed this maximum rating.

For the weights, refer to § 10.1.5.

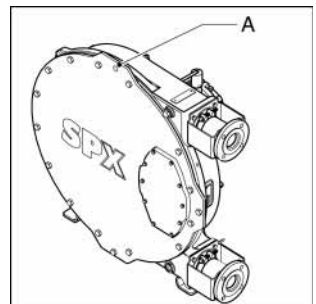

Maximum rating of the lifting point of the pump head				
SPX40	SPX50	SPX65	SPX80	SPX100
200 kg	390 kg	670 kg	1020 kg	1580 kg
441 lbs	860 lbs	1477 lbs	2249 lbs	3483 lbs

The complete hose pump, i.e. pump head, gearbox and electric motor, must be lifted using the lifting point of the pump head plus additional support using suitably rated straps or slings (A). Never exceed the maximum rating of the lifting point of the pump head.

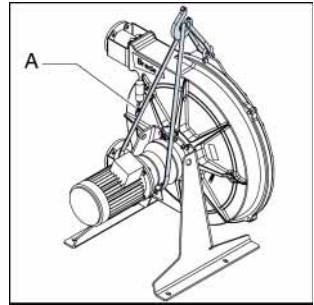

	<p><b>WARNING</b></p> <p>If the pump is to be lifted ensure that all standard lifting practices are adhered to and carried out by qualified personnel only.</p>
--	-----------------------------------------------------------------------------------------------------------------------------------------------------------------

	<p><b>WARNING</b></p> <p>Do not use the holes in the pump supports to lift the hose pump.</p>
--	-----------------------------------------------------------------------------------------------

### 5.5 Placing the pump

Position the pump on a horizontal surface. Use suitable anchor bolts to attach the pump to the floor surface.

	SPX40	SPX50	SPX65	SPX80	SPX100
Thread	3/4-10 UNC	3/4-10 UNC	3/4-10 UNC	7/8-9 UNC	7/8-9 UNC

## **6 COMMISSIONING**

### **6.1 Preparations**

1. Connect the electric motor in conformance with the locally applicable rules and regulations. Ensure qualified personnel carry out the electrical installation work.
2. Check that the lubricant level is above the minimum level line in the inspection window. If necessary add Watson-Marlow Bredel Genuine Hose Lubricant via the breather/vent plug. See also § 7.4.
3. Check the rotation of the rotor. The rotational direction of the rotor must match the configuration of suction and discharge piping.
4. Check that the correct number of shims corresponds with your application. Refer to § 10.1.6.  
For adjusting the compression force of the hose, refer to § 7.8.
5. Check that the breathers on the rear of the pump and on the gearbox are free from any obstruction.
6. Check to ensure the gearbox has been filled with the proper oil level.

### **6.2 Commissioning**

1. Connect the pipework. Make sure that there are no obstructions such as closed valves.
2. Switch on the hose pump.
3. Check the rotation of the pump rotor.

## COMMISSIONING

---

4. Check the capacity of the hose pump. If the capacity differs from your specification, follow the instructions in chapter 9 or consult your Watson-Marlow Bredel representative.
5. Check the hose pump in accordance with points 1 to 4 of the maintenance table from § 7.2.

## 7 MAINTENANCE

### 7.1 General

**WARNING**

Only use original Watson-Marlow Bredel parts when maintaining the hose pump. Watson-Marlow Bredel cannot guarantee a correct functioning and any consequential damage that occurs from the use of non-original Watson-Marlow Bredel components. See also chapters 2 and 3.

**WARNING**

If the cover is removed when the pump hose is still in the pump head, the compression forces on the pump hose may cause damage to the pump housing, rotor and pump hose. The pump hose needs to be safely removed before the cover can be replaced. Normally the compression forces are partially compensated by the cover.

### 7.2 Maintenance and periodic inspections

The following diagram shows the maintenance and periodic inspections that need to be carried out on the hose pump to guarantee an optimal safety, operation and life of the pump.

Point	Action	To be carried out	Remark
1	Check the lubricant level.	Before startup of the pump and on a scheduled interval during operation.	Make sure that the lubricant level is above the minimum level line in the inspection window. If necessary refill the lubricant. See also § 7.4.
2	Check the pump head for any leakage of lubricant around the cover, the flanges and the rear of the pump head.	Before startup of the pump and on a scheduled interval during operation.	See § 9.
3	Check the gearbox on any leakage.	Before startup of the pump and on a scheduled interval during operation.	In case of leakage consult your Watson-Marlow Bredel representative.
4	Check pump for deviating temperature or strange noises.	On a scheduled interval during operation.	See § 9.
5	Check pressing shoes for excessive damage.	When replacing the pump hose.	See § 7.6.
6	Internal cleaning of the pump hose.	Cleaning of the system or product change.	See § 7.3.
7	Replacing pump hose.	Preventive, this means after 75% of the hose life of the first hose.	See § 7.6.
8	Changing lubricant.	After every 2 <sup>nd</sup> hose change or after 5,000 service hours, whichever comes first or after hose rupture.	See § 7.4
9	Changing oil in gearbox.	After the first 100 service hours and subsequently annually or every 2500 service hours.	See § 7.5.
10	Replacing pump seal.	If necessary.	See § 7.7.3.

Point	Action	To be carried out	Remark
11	Replacing wear ring.	If necessary.	See § 7.7.3.
12	Replacing pressing shoes.	Wear on the running surface.	See § 7.7.2.
13	Replacing bearings.	If necessary.	See § 7.7.4.
		In potentially explosive atmospheres preventive after 20,000 hrs. service or when damage is suspected.	See § 7.7.2. Exclusively applicable in potentially explosive atmospheres (Group II Appliances, category 2 G c k T4).

### 7.3 Cleaning pump hose

Running the pump with clean water can clean the inside of the pump hose. If a cleaning fluid is added to the water, attention must be given to its compatibility with the hose liner material, and also the temperature at which the cleaning procedure will be performed. Sometimes a cleaning sponge can be very helpful. With many products, it is necessary to clean the pump hose immediately once the pump is stopped to avoid sedimentation and/or hardening of the product within the hose that can cause damage upon restart.

### 7.4 Changing lubricant

- Place a tray (A) under the drain plug in the bottom of the pump. Remove the drain plug (B). Catch the lubricant from the pump housing in the tray. Check that the sealing ring (C) is not damaged and replace it if necessary. Position the drain plug and tighten it firmly.

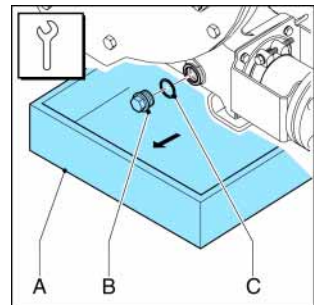

2. The pump housing can be filled with lubricant via the breather/vent (A) on the rear of the pump housing. For this purpose remove the breather cap (B) and position a funnel (C) in the breather. In order to facilitate the filling with lubricant the plug (D) on the front of the pump housing can be removed. Pour the lubricant in the pump housing via the funnel. Continue until the lubricant level has reached above the minimum level line.

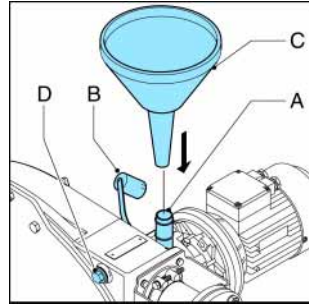

	<p>For the required quantity of lubricant, refer to § 10.1.4.</p>
--	-------------------------------------------------------------------

### 7.5 Changing oil in gearbox

1. Isolate the pump from the electrical supply.
2. Position a tray under the gearbox. Remove plug (A) and drain the gearbox.
3. The plug (A) is magnetically loaded. In this way metal particles in the oil are pulled to the plug. Clean the plug and remove any metal particles if necessary. Check that the sealing ring is not damaged and replace it if necessary. Place the plug back in the gearbox and tighten it firmly.

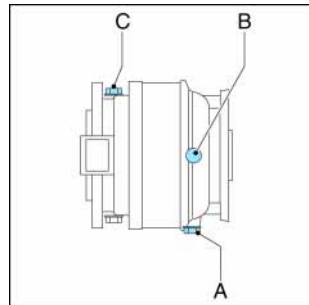

4. Remove level plug (B) and breather (C). Position a funnel in the hole of breather (C) and fill the gearbox with oil until the oil just comes out of the level plug hole (B). Place plug (B) and plug (C) back and tighten them firmly.



For the required lubricant, refer to § 10.2.



**WARNING**

To prevent damage to the gears, do not operate the pump unless proper volume of oil is filled into the gearbox.

5. Switch on the electrical supply to the pump.

## 7.6 Replacing pump hose

### 7.6.1 Removing pump hose



**CAUTION**

For all weight and torque adjustment, please refer to the technical information section at the rear of this manual.

1. Isolate the pump from the electrical supply.
2. Close any shut-off valves in both the suction and discharge line to minimize product loss.

3. Place a tray (A) under the drain plug in the bottom of the pump head. The tray must be large enough to contain the lubricant, possibly contaminated with product fluid, from the pump head. Remove the drain plug (B). Catch the lubricant from the pump housing in the tray. Check that the breather vent mounted on the rear is not obscured. Check that the sealing ring (C) is not damaged and replace it if necessary. Position the drain plug and tighten it firmly.

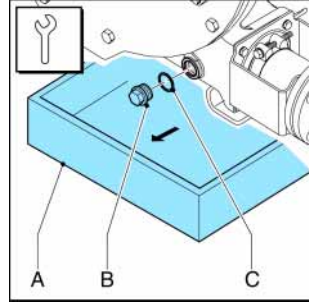

4. Loosen the retaining bolts (A) of both the suction and discharge line (B). Disconnect the suction and discharge lines.

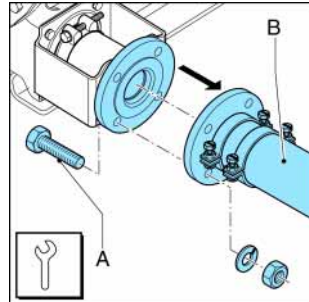

5. Loosen hose clamp (A) of both the inlet and outlet ports by loosening retaining bolt (B).

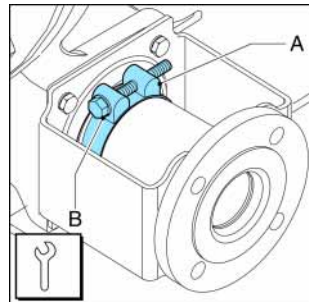

6. Pull the insert (B) from the hose and remove the flanges (A). Carry out this procedure both for the inlet and outlet ports.

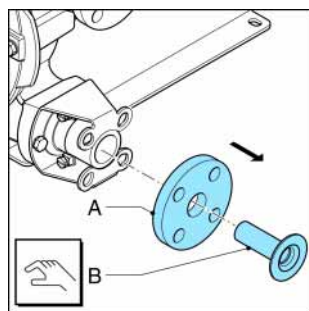

7. Loosen the retaining bolts (A) of the flange bracket (B) and remove the bolts. Slide the flange bracket and the hose clip (C) off the hose. Carry out this procedure both for the inlet and outlet ports.

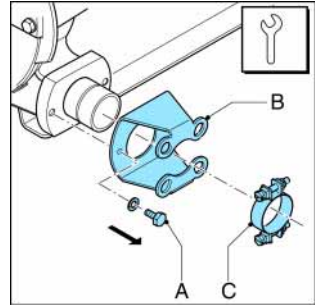

8. Slide off the sealing ring (A). Check that the sealing ring is not deformed or damaged and replace it if necessary. Carry out this procedure both for the inlet and outlet ports.

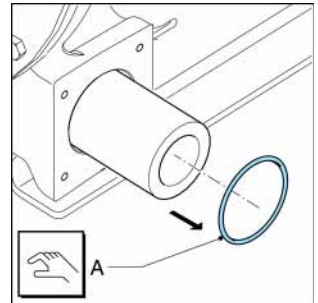

9. Connect the pump to the electrical supply.



**WARNING**

Removal of the hose is a powered process and requires rotation of the pump. Ensure body and tools are clear from moving parts prior to proceeding with hose removal.

10. Power out the hose (A) from the pump chamber by jogging the drive motor.

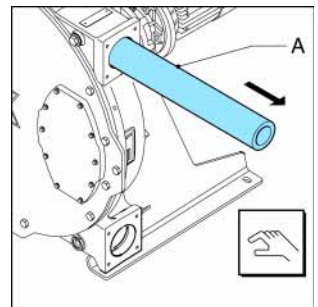

### 7.6.2 Cleaning the pump head

	<p><b>WARNING</b></p> <p>Never remove the cover when the pump hose is in the pump head. The compression forces on the pump hose are partially compensated by the cover. By removing the cover with the hose installed, subsequent damage can occur.</p>
--	---------------------------------------------------------------------------------------------------------------------------------------------------------------------------------------------------------------------------------------------------------

	<p><b>WARNING</b></p> <p>The cover is heavy. For all weight and torque adjustment, please refer to the technical information section at the rear of this manual.</p>
--	----------------------------------------------------------------------------------------------------------------------------------------------------------------------

1. Isolate the pump from the electrical supply.
2. Use lifting hole (D) to move the cover. Remove the cover (B) by loosening the retaining bolts (A).
3. Check the sealing ring (C) and replace it if necessary.
4. Rinse the pump head with clean water and remove all residues. Make sure that no rinsing water remains in the pump head.

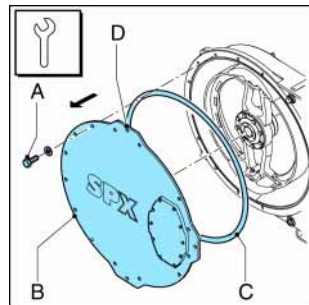

5. Check the pressing shoes for wear or damage and replace them if necessary. Refer to § 7.7.2. Also see the maintenance diagram in § 7.2.

**CAUTION**

When the pressing shoes are worn the compression force of the hose decreases. If the compression force is too low, this results in a loss of capacity by the backflow of the liquid to be pumped. Backflow results in a reduction of the life of the pump hose.

6. Replace the cover and fasten the retaining bolts with the correct torque. Refer to § 10.1.7.
7. Switch on the electrical supply to the pump.

### 7.6.3 Fitting the pump hose

**WARNING**

Fitting the pump hose is a powered process and requires pump rotation. Ensure the pump cover is properly fitted and that body and tools are clear from moving parts.

**WARNING**

For all weight and torque adjustment, please refer to the technical information section at the rear of this manual.

1. Clean the (new) pump hose on the outside and fully lubricate it with Watson-Marlow Bredel Genuine Hose Lubricant.
2. Turn on the pump and note the direction of the pump rotation.

3. Fit the pump hose (A) via one of the ports – whichever is the suction based on rotation direction. Feed the hose into the port and allow the pressing shoe to draw the hose in the pump housing. The rotor will move the hose.
4. Stop the motor when the hose sticks out equally from both sides of the pump housing.

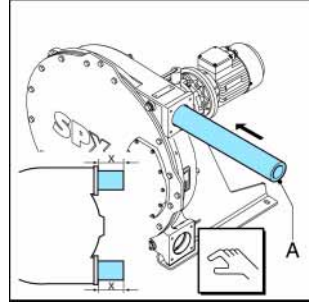

5. First fit the inlet port. Fit the sealing ring. Before mounting, check that the sealing ring (A) is not deformed or damaged and replace it if necessary.

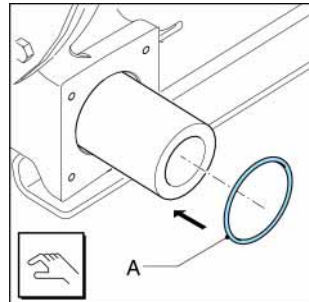

6. Before fitting check that the hose clamp is not damaged and replace it if necessary. Slide the flange bracket (B) and the hose clamp (C) over the hose together. Align the holes in the flange bracket with the ones at the front of the port. Position the four retaining bolts (A) and tighten them until they are approx. 5 mm (3/16") from the port, so that the gap between the flange bracket and the port remains.

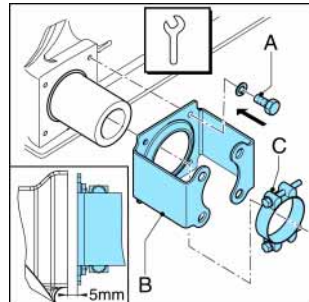

7. Slide insert (B) in the flange (A) and press the insert in the hose. If necessary lubricate the insert with Watson-Marlow Bredel Genuine Hose Lubricant in order to simplify mounting. Make sure that the holes in flange (A) are aligned with the holes in flange bracket (C). Check that the insert is in the correct place. If the insert is not positioned correctly the product to be pumped may leak or the lubricant may leak.

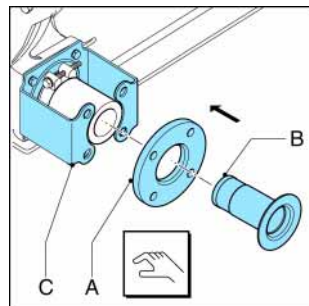

8. Fit the suction line (B) and the retaining bolts (A). Tighten the retaining bolts with the correct torque. Refer to § 10.1.7.

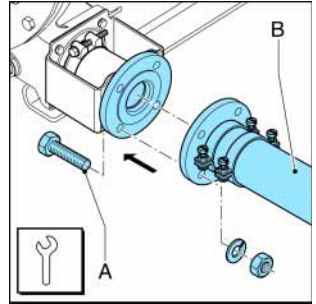

9. Turn the rotor in such a way that the hose (A) is pressed firmly against the flange surface (B).

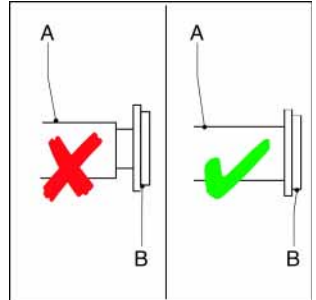

10. Now fully tighten the retaining bolts (A) of the flange bracket (B). Make sure the bolts are tightened with the correct torque. Refer to § 10.1.7.

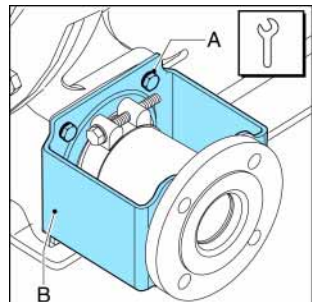

11. Position hose clamp (A) against O-ring chamber of the flange bracket (B) and fasten the retaining bolt. Make sure the bolts are tightened with the correct torque. Refer to § 10.1.7.

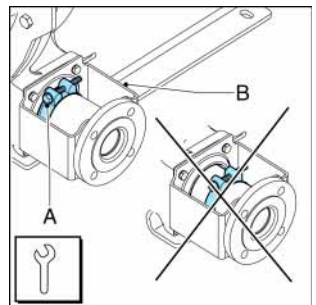

12. Now fit the other port. For this port proceed in the same way as described above for the inlet port.

13. Fill the pump housing with Watson-Marlow Bredel Genuine Hose Lubricant. Refer to § 7.4.

## 7.7 Exchanging replacement parts

### 7.7.1 General



#### CAUTION

Items may be heavy. For all weight and torque adjustments for replacement procedures under this section, please refer to the technical information in chapter 10.

### 7.7.2 Replacing pressing shoes

1. Jog the motor until the pressing shoe (B) is positioned in view of the inspection window (A).
2. Isolate the pump from the electrical supply.
3. Place a tray (A) under the drain plug (B) in the bottom of the pump head. Remove the drain plug. Drain as much Watson-Marlow Bredel Genuine Hose Lubricant until the level has lowered just below the inspection window (D). Check that the sealing ring (C) is not damaged and replace it if necessary. Position the drain plug and tighten it firmly

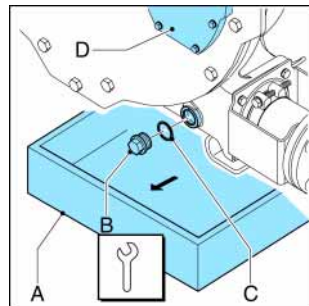
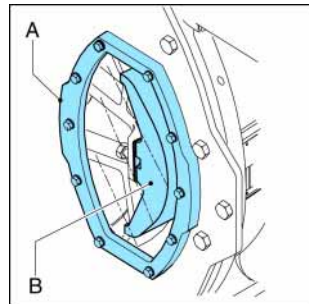

4. Loosen the retaining bolts (A) of the inspection window (B) and remove the bolts. Remove the inspection window. Care must be taken not to damage the gasket (C).

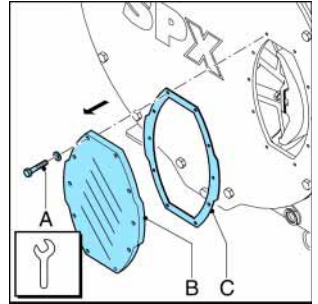

5. Loosen the retaining bolt(s) (A) of pressing shoe (B) a few turns. Remove the shims (C) if present. Loosen the retaining bolt(s) (A) of pressing shoe (B) completely and remove the pressing shoe.

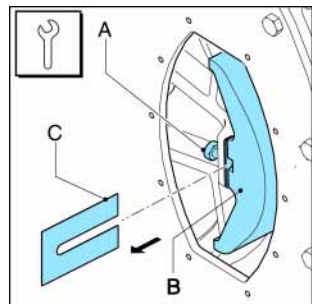

6. Position the (new) pressing shoe (A), check that the NordLock®-rings (B) have been positioned correctly and tighten the retaining bolt(s) a few turns.

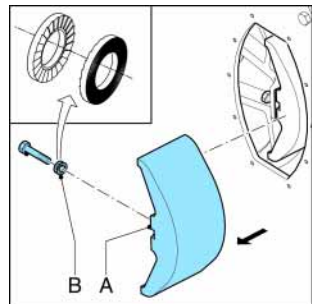

7. Fit the removed shims (A) again. Tighten the retaining bolt(s) (B) with the correct torque. Refer to § 10.1.7.

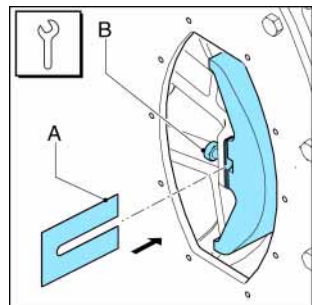

8. Refit the inspection window (B). Check the inspection window gasket (C) for damage and replace if necessary. Make sure that all bolts (A) are refitted and that they are tightened in the correct order, diagonally opposite each other.
9. Switch on the electrical supply.
10. Jog the motor until the second pressing shoe is positioned in front of the inspection window.
11. Isolate the pump from the electrical supply.
12. Repeat the procedure for removing and fitting this second pressing shoe by repeating steps 4 through 9.
13. Refill the lubricant. Refer to § 7.4.

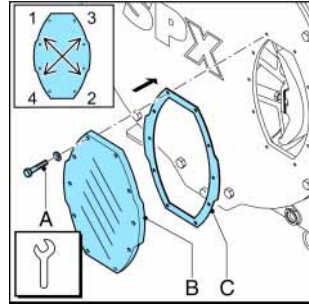

### 7.7.3 Replacing seal and wear ring

1. Remove the pump hose. Refer to § 7.6.1.
2. Isolate the pump from the electrical supply.
3. Use lifting hole (D) to move the cover. Remove the cover (B) by loosening the retaining bolts (A). Check the sealing ring (C) of the pump cover for damage.
4. Remove the retaining bolts (A) of the drive shaft (B) and remove the drive shaft. Check the sealing ring (C) for damage.

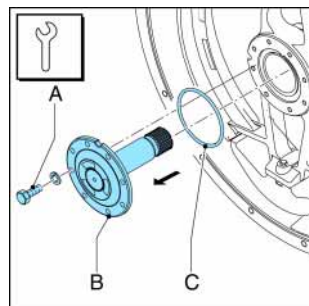
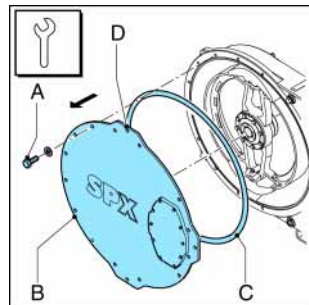

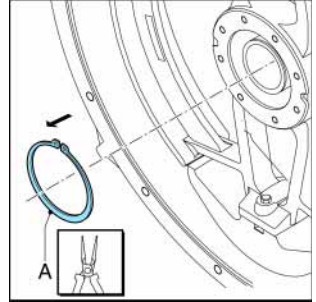

<b>i</b>	If the drive shaft cannot be removed manually, use a screwdriver in the slots in the rotor provided for this purpose.
----------	-----------------------------------------------------------------------------------------------------------------------

5. Remove the rotor retaining circlip (A), which locks the rotor on the hub. Use the correct tools to do this.

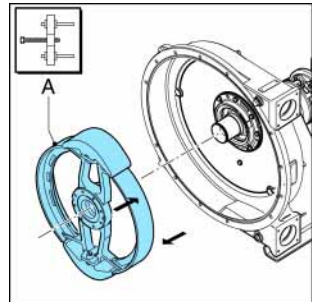

6. Fit the necessary lifting means before dismantling the rotor. Extract the rotor (A) from the hub. A suitable puller or similar extraction tool will be required during this stage of the disassembly.



	<p><b>WARNING</b></p> <p>When removing the rotor a belt or similar lifting aid must carry the weight of the rotor. For the specific weight of the rotor, refer to § 10.1.5.</p>
-----------------------------------------------------------------------------------	---------------------------------------------------------------------------------------------------------------------------------------------------------------------------------

7. Remove the seal (A) from the hub (B). Clean and degrease the bore.
8. Fit a new seal using a wooden block and hammer. Carefully hit the seal crosswise and with equal strength in the bore until it touches the hub. The seal must be fitted in the correct orientation (C). Make sure that the open side points to the pump cover.

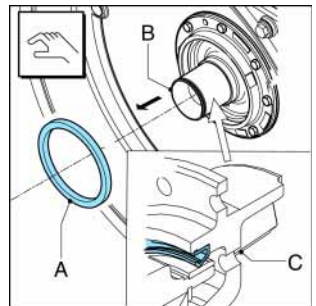

9. Support the rotor with wooden blocks at 90° to the spokes, with the ring (A) facing down. Position a suitable punch against the rear of the glued wear ring. Prevent damage to the wear ring seat or other parts.

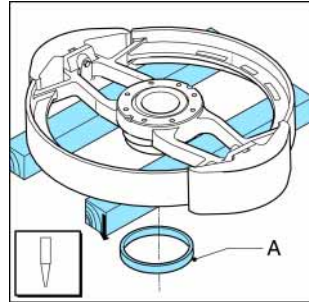

10. Turn the rotor over. Make sure that the seats of the new wear ring (A) and rotor are clean, dry and free of grease. Apply Loctite® type 641 or 603 both on the rotor and the wear ring. Position the new wear ring with the tapered edge facing up. Use a plastic hammer to fit the ring on the rotor until it touches the rotor completely.

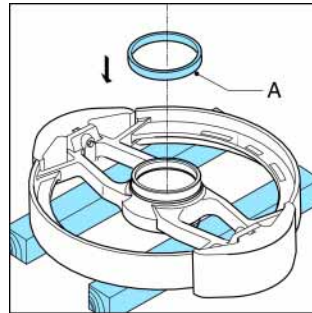

11. Check that the hub is clean and free of grease. Fit rotor (A). The bearings have been placed on the hub with a slight interference fit. Use a pressing tool to press the rotor on the hub.

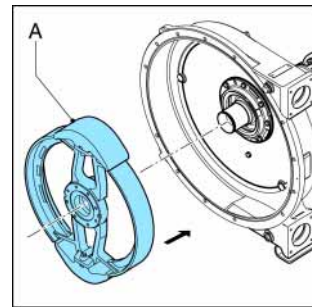

12. Check rotor retaining circlip (A) for any signs of damage and replace if necessary. Refit the circlip. Use the correct tools for this purpose.

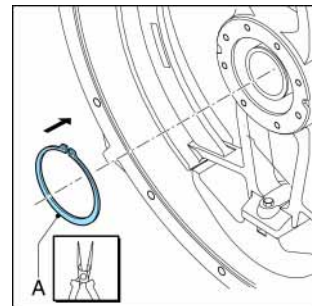

13. Heavily grease the spline (D) of the drive shaft (B) with a graphite-loaded grease. Ensure the mating faces of the drive shaft and rotor are clean, dry and free from lubricant. Check that the sealing ring (C) is not damaged and replace it if necessary. Fit the sealing ring in the groove of the shaft flange. Fit the drive shaft. Turn the rotor until the bolt holes in the drive shaft correspond with the threaded holes in the rotor. Mount the retaining bolts (A) of the drive shaft. Tighten the bolts finger-tight. Tighten them diagonally opposite to each other to the specified torque limits. Refer to § 10.1.7.

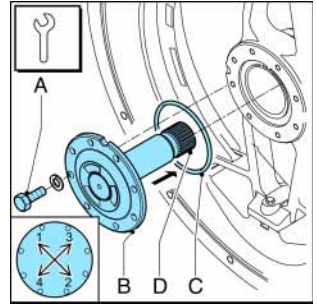

14. Replace the cover and fasten the retaining bolts with the correct torque. Refer to § 10.1.7.
15. Switch on the electrical supply to the pump.
16. Fit the (new) pump hose. Refer to § 7.6.3.

#### 7.7.4 Replacing bearings

1. Dismount the pump hose, the cover and rotor by following steps 1 through 6 from § 7.7.3.
2. Lay the rotor on a flat surface with the wear ring face up. Remove retaining circlip (A) with the correct tools.

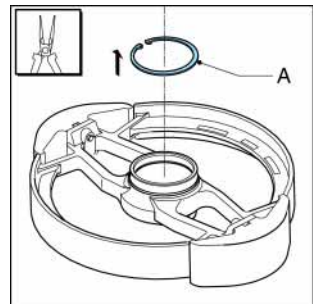

3. Turn the rotor over. Remove using the correct pressing tools, first the first bearing (C), the spacer ring (B) and the second bearing (A) from the rotor. Check the spacer ring for damage. Retain the spacer ring (B).

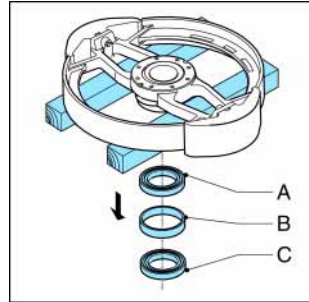

4. Turn the rotor over. Check that the hub is clean and dry. Press using the pressing tool the first bearing (C) in its place. Position the spacer ring (B). Subsequently press the second bearing (A) in its place.

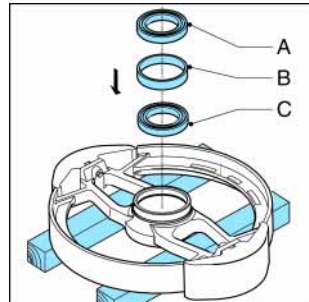

5. Refit the retaining circlip (A) in the rotor. Use the correct tools for this purpose.

6. Fit the rotor, the cover and pump hose by following steps 11 through 16 from § 7.7.3.

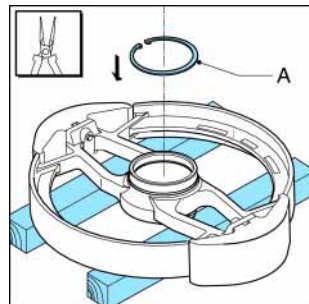

### 7.8 Adjusting hose compression force (shimming)

Fitting and removing shims is a simple action which can be carried out via the inspection window on the front of the pump housing. The pump hose or the pump cover

does not need to be removed. In order to determine the correct number of shims for your specific application refer to § 10.1.6.



**CAUTION**

Too many shims, this means a too high compression force on the pump hose, create a too high load on the pump head and pump hose, which results in a reduction of the life of the pump hose and bearings.



**CAUTION**

Too few shims, this means a too low compression force on the pump hose, create a loss of yield and slip or backflow. Backflow results in a reduction of the life of the pump hose.

1. Jog the motor until the pressing shoe (B) is positioned in view of the inspection window (A).
2. Isolate the pump from the electrical supply.
3. Place a tray (A) under the drain plug (B) in the bottom of the pump head. Remove the drain plug. Drain as much Watson-Marlow Bredel Genuine Hose Lubricant until the level has lowered just below the inspection window (D). Check that the sealing ring (C) is not damaged and replace it if necessary. Position the drain plug and tighten it firmly.

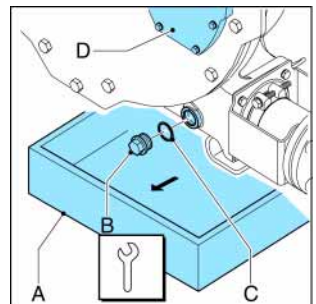
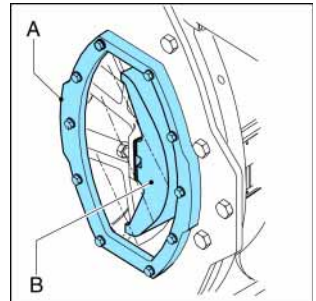

4. Loosen the retaining bolts (A) of the inspection window (B) and remove the bolts. Remove the inspection window. When doing this prevent the gasket (C) from damaging.

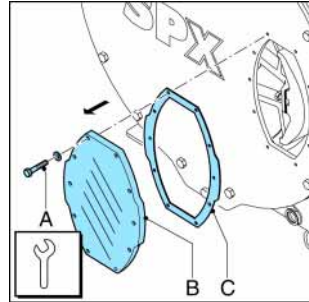

5. Loosen the retaining bolt(s) (A) of pressing shoe (B) a few turns. Fit the shims (C) or remove them, until the correct number of shims is present. Refer to § 10.1.6. Tighten the retaining bolt(s) of the pressing shoe with the correct torque. Refer to § 10.1.7.

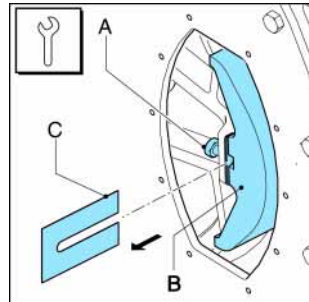

6. Check the inspection window gasket for damage and replace if necessary. Refit the inspection window (B). Make sure that all bolts (A) are refitted and that they are tightened in the correct order, diagonally opposite each other, to the specified torque limits. Refer to § 10.1.7.

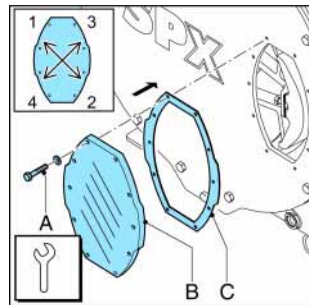

7. Switch on the electrical supply.
8. Jog the motor until the second pressing shoe is positioned in front of the inspection window.
9. Isolate the pump from the electrical supply.
10. Repeat the procedure for this pressing shoe by repeating steps 4, 5, 6 and 7.
11. Refill the lubricant via the breather. Refer to § 7.4.

## 7.9 Fitting options

### 7.9.1 Fitting a high-level float switch

For use in non-explosive environments: Switch rating: 230 VAC, 2 A, max. power load 40 VA.



For explosive environments, contact your Watson-Marlow Bredel representative.

1. Remove the standard breather (A) on the rear of the pump, by removing it from crimp connector (B).

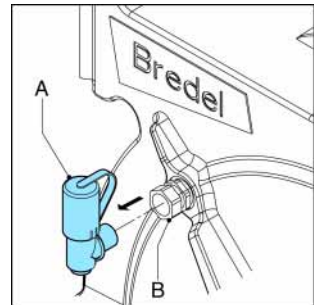

2. Slide the standard breather cap (A) from breather (B).

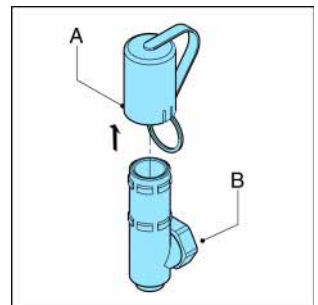

3. Replace the standard breather cap with the breather cap with high level float switch (A) and slide it over breather (B).

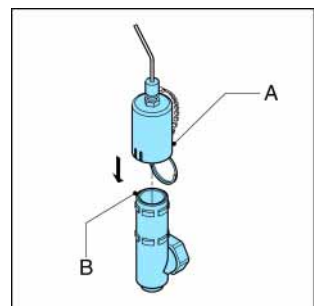

4. Fit the breather (A) on the rear of the pump, by mounting it to crimp connector (B).
5. Connect the high-level float switch to the electrical supply. Bear in mind that the electrical contact of the float switch is normally closed (NC). When the lubricant level is (too) high the contact will open.

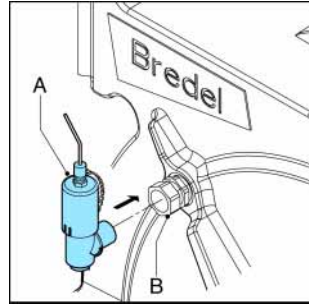

### 7.9.2 Fitting a low level float switch

For use in non-explosive environments: Switch rating: 230 VAC, 2 A, max. power load 40 VA.

	<p>For explosive environments, contact your Watson-Marlow Bredel representative.</p>
--	--------------------------------------------------------------------------------------

1. If the pump is filled with lubricant this must be removed first. Place a clean tray (A) under the drain plug in the bottom of the pump. Remove the drain plug (B). Catch the lubricant from the pump housing in the tray. Check the sealing ring (C) for damage.

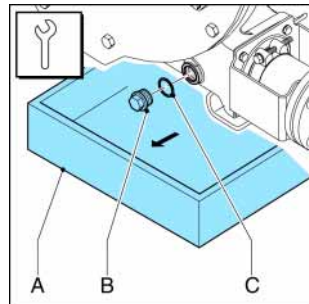

2. Fit the crimp connector (A) together with the sealing ring (B) to the pump housing. Fit the low-level float switch (C) to the crimp connector (A).

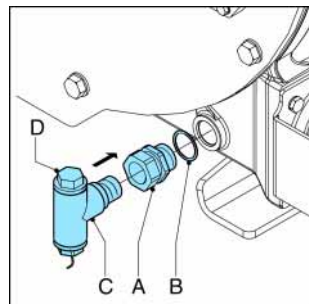

3. Connect the high-level float switch to the auxiliary power circuit via the 1.5 meter long PVC cable (2 x 0.24 mm<sup>2</sup>). Bear in mind that the electrical contact of the float switch is normally closed (NC). When the lubricant level is (too) high the contact will open.

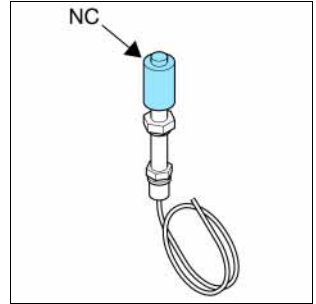

Specifications	
Voltage:	Max. 230 V AC/DC
Current:	Max. 2 A
Power:	Max. 40 VA



Where the floater is constructed to stop the equipment, operating has to be arranged so that the stop function locks-out, preventing the equipment from being re-started without re-setting. Check if the floater is mounted with the NC sign at the top.

4. Refill the pump housing to the proper level with Watson-Marlow Bredel Genuine Hose Lubricant. Refer to § 7.4.
5. Breath the float switch by carefully opening plug (D) until lubricant escapes. Subsequently close the plug again.

**7.9.3 Fitting revolution counter**

1. Remove one of the pressing shoes of the rotor by following steps 1 through 5 from § 7.7.2.
2. Replace pressing shoe by the special pressing shoe with a magnet (A) by following the steps 6 through 8 from § 7.7.2.

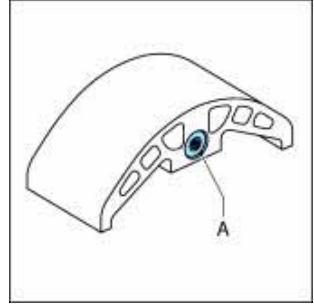

3. Fit the inductive sensor (A) in plug (B) and adjust it to dimension 'X' as indicated in the table below.

Pump type	Dimension "X" [mm]
SPX 40	32 +0/-1
SPX 50	32 +0/-1
SPX 65	32 +0/-1
SPX 80	45 +0/-1
SPX 100	45 +0/-1

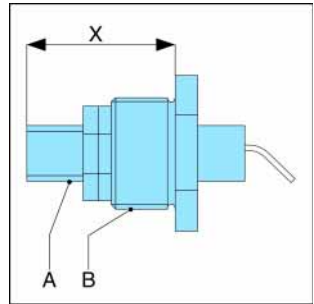

4. Tighten the adjusting nuts with a torque of 25 Nm (220 lbf in).
5. Remove a plug (A) and the sealing ring (B) on the back side of the pump housing. Check that the sealing ring (B) is not damage and replace it if necessary.

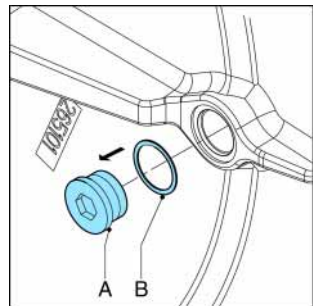

6. Fit the plug with the inductive sensor (A) together with sealing ring (B) on the pump housing.
7. Refill the pump housing to the proper level with Watson-Marlow Bredel Genuine Hose Lubricant. Refer to § 7.4.
8. Connect the sensor via the 2 meter long PVC cable (3 x 0.34 mm<sup>2</sup>).

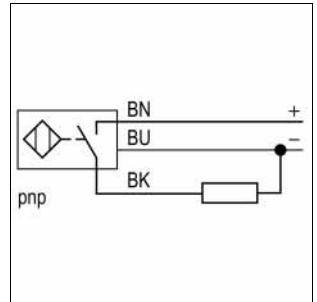
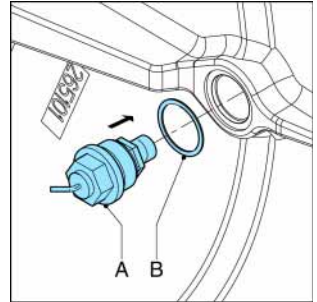

Specifications	
Voltage:	10...30 VDC
Current:	Max. 200 mA

	<p><b>WARNING</b> Contact your Watson-Marlow Bredel representative for proper connection of the sensor.</p>
--	-----------------------------------------------------------------------------------------------------------------

	<p>For explosive environments, contact your Watson-Marlow Bredel representative.</p>
--	--------------------------------------------------------------------------------------

## 8 STORAGE

### 8.1 Hose pump

- Store the hose pump or pump parts in a dry area. Make sure that the hose pump or pump parts are not exposed to temperatures lower than  $-40\text{ }^{\circ}\text{C}$  ( $-104\text{ }^{\circ}\text{F}$ ) or higher than  $+70\text{ }^{\circ}\text{C}$  ( $158\text{ }^{\circ}\text{F}$ ).
- Cover the openings of the inlet and outlet ports.
- Prevent corrosion of untreated parts. For this purpose use the correct protection or packaging means.
- After a long period of standstill or storage (i.e. pump is idle for a period of longer than one continuous month), the static load on the pump hose may cause permanent deformation, which will reduce the life of the pump hose and may cause difficulty in starting.

To prevent deformation of the hose, pump motor should be jogged on a monthly basis to allow repositioning of the shoe on the hose.

If motor jogging is not possible and long term shutdown is expected, remove a pressing shoe and turn the rotor so far that the second pressing shoe is in front of the inspection window. In this way there is no load put on the pump hose. When startup is again expected, replace the pressing shoes, the proper number of shims, and the lubricant.

### 8.2 Pump hose

- Store the pump hose in a cool and dark room. After 2 years the hose material will age, which will reduce the life of the hose.

**9 TROUBLESHOOTING**

	<p><b>WARNING</b></p> <p>Disconnect and lock the power supply to the pump drive before any work is carried out.</p> <p>Wait two minutes to make sure that the capacitors have discharged. This is necessary when the motor is fitted with a Variable Frequency Drive (VFD) and has single phase power supply.</p>
-----------------------------------------------------------------------------------	-------------------------------------------------------------------------------------------------------------------------------------------------------------------------------------------------------------------------------------------------------------------------------------------------------------------

If the hose pump does not function (correctly), consult the following checklist to see if you can remedy the error yourself. If this is not the case, contact your Watson-Marlow Bredel representative.

<b>Problem</b>	<b>Possible cause</b>	<b>Correction</b>
<b>Failure to operate.</b>	No voltage.	Check that the supply power switch is on.  Check the electrical supply is available at the pump. Check current limit of electrical source to pump.
	Stalled rotor.	Check hose and lubricant was loaded properly and pressing shoes are shimmed properly.
	Lubricant level monitoring system has been activated.	Confirm that the lubricant level monitoring system has stopped the pump. Check the lubricant level and proper functioning of the level switch(es).

Problem	Possible cause	Correction
<b>High pump temperature.</b>	Non-standard hose lubricant used.	Consult the Watson-Marlow Bredel representative for the correct lubricant.
	Low lubricant level.	Add Watson-Marlow Bredel Genuine Hose Lubricant. For the required amount of lubricant refer to § 10.1.4.
	Product temperature too high.	Consult the Watson-Marlow Bredel representative about the maximum temperature range of the product.
	Internal friction on the hose caused by blocked or poor suction characteristics.	Check pipe work/valves for blockages. Ensure that the suction pipe work is as short as possible and that the diameter is large enough.
	Over-shimming of the pump rotor shoes.	Consult the diagram. Refer to § 10.1.6. Remove excess shims.
	High pump speed.	Reduce pump speed to a minimum. Consult with your Watson-Marlow Bredel pump representative for advice on optimum pump speeds.

<b>Problem</b>	<b>Possible cause</b>	<b>Correction</b>
<b>Low capacity / pressure.</b>	Shut-off valve in the suction line (partly) closed.	Fully open the shut-off valve.
	Under shimming of the pressing shoes.	Check shimming. Refer to specifications in § 10.1.6. Fit the correct number of shims.
	Hose failure or badly worn hose.	Replace hose. Refer to § 7.6.
	Partial blockage of the suction line or no product in suction vessel.	Ensure that the suction line is clear of blockages and that sufficient product is available.
	Connections and hose clamps not correctly mounted, which allows the pump to draw in air.	Tighten connections and hose clamps.
	You are starving the pump because the speed is too high for your suction pressure.	Consult your Watson-Marlow Bredel representative for a recommendation.
<b>Vibration of the pump and pipe work.</b>	Suction and discharge lines are not secured correctly.	Check and secure pipe work.
	High pump speed with long suction and discharge lines or high relative density or a combination of these factors.	Reduce pump speed. Reduce the line lengths on both suction and discharge where possible. Consult your Watson-Marlow Bredel representative for a recommendation.
	Too narrow diameter of suction and/or discharge line.	Increase the diameter of the suction/discharge lines.

Problem	Possible cause	Correction
<b>Broken front cover bolts.</b>	Pump cover removed with the hose in the pump.	Never remove the pump cover when the hose is still in the pump.
<b>Short hose life.</b>	Chemical attack of the hose.	Check the compatibility of the hose material with the product to be pumped. Consult your Watson-Marlow Bredel representative for correct hose selection.
	High pump speed.	Reduce pump speed.
	High discharge pressures.	It is recommended that the pressure on the discharge of the pump does not exceed 1600 kPa (230 psi). Check that the discharge line is not blocked, the shut-off valves are fully opened and the pressure relief valve functions properly (if present in the discharge line).
	High product temperature.	Consult your Watson-Marlow Bredel representative for correct hose selection.
	High pulsations.	Restructure the discharge and inlet conditions.
<b>Hose pulled into the pump.</b>	Insufficient or no hose lubricant in the pump head.	Add extra lubricant. Refer to § 7.4.
	No Watson-Marlow Bredel Genuine Hose Lubricant used.	Consult the Watson-Marlow Bredel representative for the correct lubricant.
	Extremely high inlet pressure - larger than 300 kPa (43.5 psi).	Reduce the inlet pressure.

Problem	Possible cause	Correction
<b>Lubricant leakage at flange bracket.</b>	Hose blocked by an incompressible object in the hose. The hose cannot be compressed and will be pulled into the pump housing.	Remove hose, check for blockages and replace if necessary.
	Bolts of flange bracket loose.	Tighten to the specified torque settings. Refer to § 10.1.7.
	Bolts of hose clamps loose.	Tighten to the specified torque settings. Refer to § 10.1.7.
<b>Leakage from the rear of the pump housing "Buffer zone".</b>	Damaged wear or seal ring.	Replace wear or seal ring.
<b>Motor running, but rotor not.</b>	Pump shaft sheared at undercut from overload condition.	Follow installation procedure supplied with replacement shaft. Check process conditions to prevent reoccurrence of overload.

**10 SPECIFICATIONS**

**10.1 Pump head**

**10.1.1 Performance**

Description	Unit	SPX40	SPX50	SPX65	SPX80	SPX100
Max. capacity, continuous	m <sup>3</sup> /h	6.0	10.5	20.0	28.0	36.0
	GPM	26.5	46.0	88.0	123.0	159.0
Max. capacity, intermittently*	m <sup>3</sup> /h	9.6	17.5	32.0	42.0	60.0
	GPM	42.3	77	141	185	264
Capacity per revolution	l/rev	1.33	2.9	6.7	11.7	20.0
	Gal/rev	0.351	0.766	1.77	3.09	5.28
Max. permissible working pressure	kPa	1600				
	PSI	232				
Permissible ambient temperature	°C	-20 to +45				
	°F	-4 to 113				
Permissible product temperature	°C	-10 to +80				
	°F	14 to 176				
Sound level on 1 m	dB(A)	70				

\* Intermittent duty: Let the pump stand still to cool down for at least 1 hour after 2 hours of operation.

10.1.2 Materials

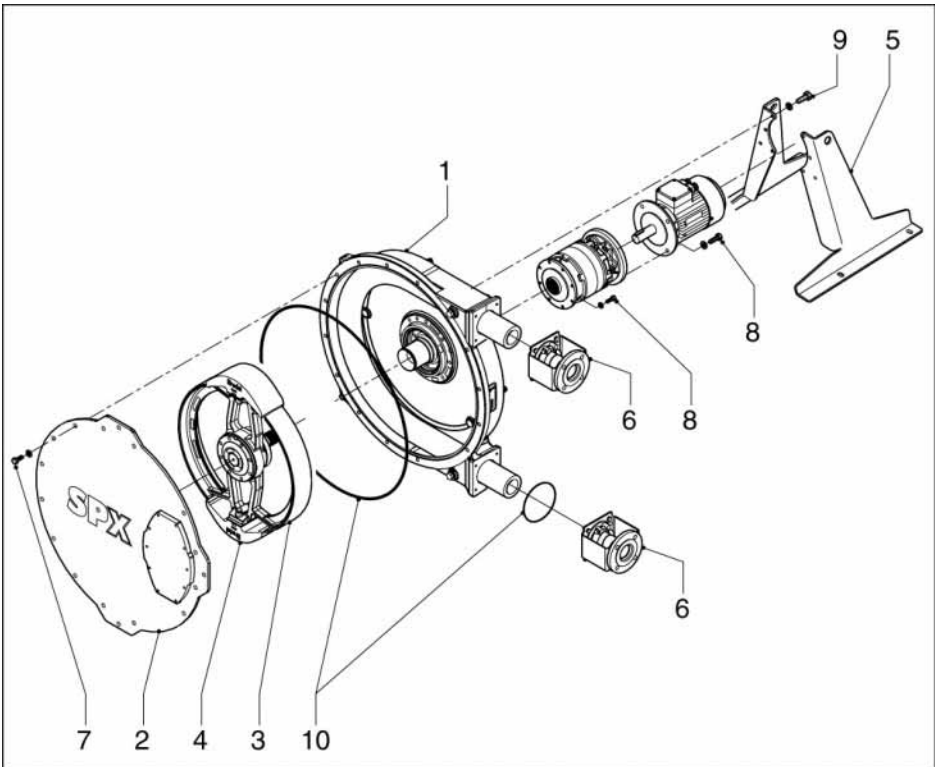

Pos	Description	Material
1	Pump housing	Cast-iron
2	Cover	Commercial grade mild steel 37
3	Pump rotor	Cast-iron
4	Pressing shoes	Aluminium (Epoxy is optional)
5	Supports	Mild steel, galvanized*
6	Hose flange brackets	Mild steel, galvanized*
7	Cover fixings	Mild steel, galvanized*
8	Motor fixings	Mild steel, galvanized*
9	Mounting material of supports	Mild steel, galvanized*
10	Seals and glands	Neoprene or Nitrile

\* Available in Stainless Steel upon request

**10.1.3 Surface treatment**

- After surface preparation, one layer of two-component acrylate is used for surface protection. Standard color is RAL 3011, however other colors are optional. Contact your Watson-Marlow Bredel representative for details on surface treatment.
- All galvanized parts, exclusive of mounting articles, have been provided with an electrolytic zinc layer of 15 - 20 microns.

**10.1.4 Lubricant table pump**

	Unit	SPX40	SPX50	SPX65	SPX80	SPX100
Lubricant	-	Watson-Marlow Bredel*	Watson-Marlow Bredel*	Watson-Marlow Bredel*	Watson-Marlow Bredel*	Watson-Marlow Bredel*
Required quantity	liters	5	10	20	40	60
	gallons	1.3	2.6	5.3	10.6	15.8

\* Watson-Marlow Bredel Genuine Hose Lubricant is registered at NSF: NSF Registration No 123204; Category Code H1. See also: [www.NSF.org/USDA](http://www.NSF.org/USDA).

The relative density of Watson-Marlow Bredel Genuine Hose Lubricant is 1.245.

	Should you require additional information with respect to the safety data sheet, consult your Watson-Marlow Bredel representative.
-----------------------------------------------------------------------------------	------------------------------------------------------------------------------------------------------------------------------------

**10.1.5 Weights**

Description	Unit	SPX40	SPX50	SPX65	SPX80	SPX100
Hose pump, maximum weight*	kg	180	325	558	930	1300
	lbs	397	717	1230	2050	2866
Pump head**	kg	121	227	398	672	1032
	lbs	267	500	877	1482	2275
Rotor	kg	14	24	40	77	118
	lbs	31	53	88	170	260
Pressing shoe	kg	0.8	1.8	4	6.6	12.6
	lbs	1.8	4.0	8.8	14.6	27.8
Pump cover	kg	16	30	62.5	106.5	195
	lbs	35.3	66	138	235	430

Description	Unit	SPX40	SPX50	SPX65	SPX80	SPX100
Drive shaft	kg	2.5	5.9	7.7	16.6	19.5
	lbs	5.5	13	17	36.6	43
Hub	kg	10	16	18	38	53
	lbs	22	35.3	39.7	83.8	117
Hose	kg	3.8	6.4	11.5	21	31
	lbs	8.4	14.1	25.4	46.3	68.3
Hose dimensions IDxODxLength	mm	40 x 66.5 x 1490	50 x 80.2 x 1820	65 x 99.2 x 2338	80 x 121.8 x 2780	100 x 144.2 x 3275
	inch	1.57 x 26.1 x 58.7	1.97 x 3.16 x 71.6	2.56 x 3.91 x 91.9	3.15 x 4.80 x 109.4	3.94 x 5.68 x 128.9

\* Maximum net weight of the hose pump with the heaviest gearbox and electric motor.

\*\* Weight of a completely mounted pump head (inclusive of hose, lubricant and supports).

### 10.1.6 Shims specifications

- When the temperatures are above 60 °C (140 °F) always use one shim less than indicated in the diagrams.
- Always round up the number of shims.

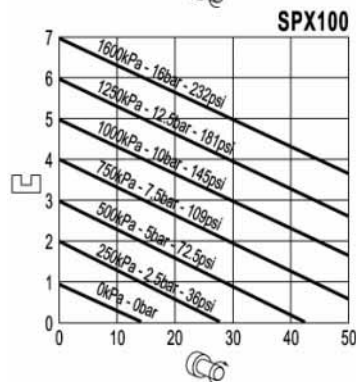
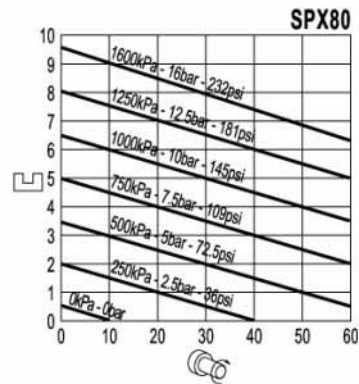
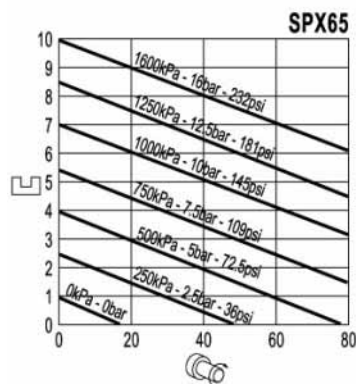
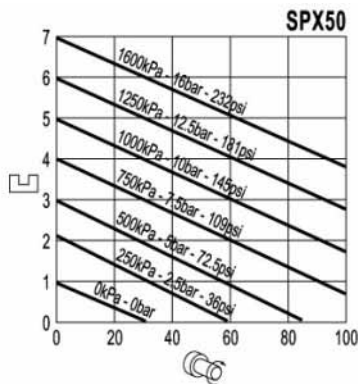
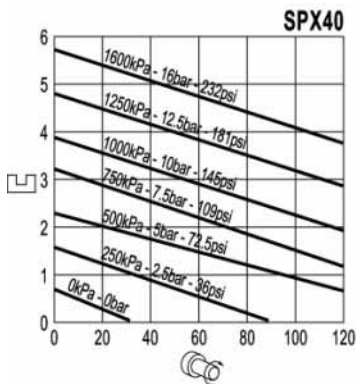

10.1.7 Torque figures

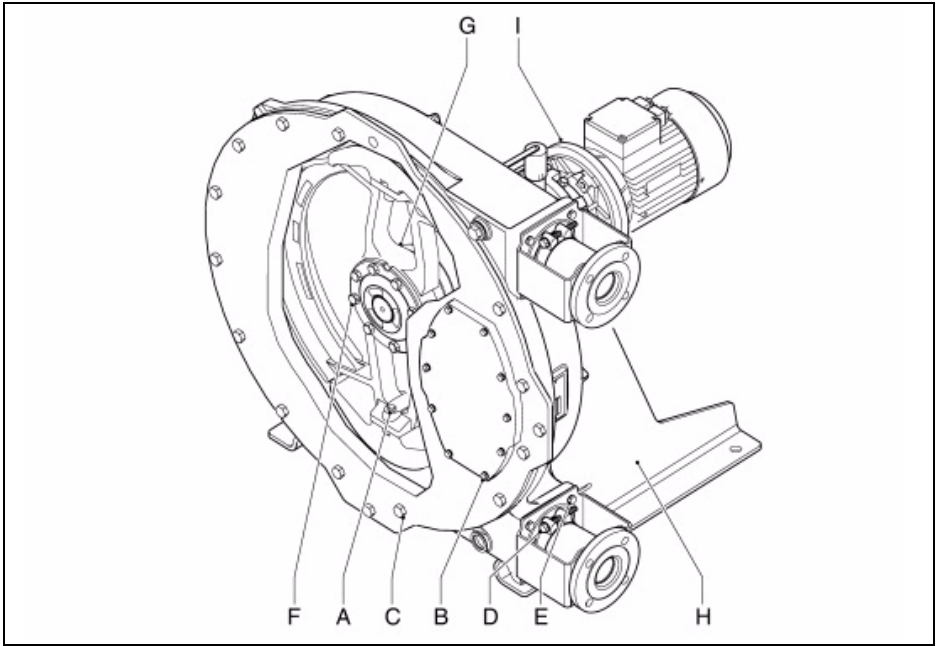

Pos	Description	Unit	SPX40	SPX50	SPX65	SPX80	SPX100
A	Pressing shoe bolt(s)	Nm	59	103	103	250	250
		lbs in	522	911.6	911.6	2212.5	2212.5
B	Inspection window bolts	Nm	5	8	8	8	8
		lbs in	44.25	70.8	70.8	70.8	70.8
C	Cover bolts	Nm	50	85	210	210	400
		lbs in	442.5	752.25	1858.5	1858.5	3540
D	Hose clamp	Nm	25	40	40	40	40
		lbs in	221.25	354	354	354	354
E	Flange bracket bolts	Nm	25	50	50	85	85
		lbs in	221.25	442.5	442.5	752.25	752.25
F	Drive shaft bolts	Nm	25	50	85	210	210
		lbs in	221.25	442.5	752.25	1858.5	1858.5

Pos	Description	Unit	SPX40	SPX50	SPX65	SPX80	SPX100
G	Hub bolts	Nm	50	50	85	210	210
		lbs in	442.5	442.5	752.25	1858.5	1858.5
H	Support bolts	Nm	50	50	85	210	210
		lbs in	442.5	442.5	752.25	1858.5	1858.5
I	Gearbox bolts	Nm	25	85	85	85	135
		lbs in	221.25	752.25	752.25	752.25	1194.75

Pos	Description	Thread, A/F				
		SPX40	SPX50	SPX65	SPX80	SPX100
A	Pressing shoe bolt(s)	M10 17 mm	M12 19 mm	M12 19 mm	M16 24 mm	M16 24 mm
B	Inspection window bolts	M6 10 mm	M8 13 mm	M8 13 mm	M8 13 mm	M8 13 mm
C	Pump cover bolts	M10 17 mm	M12 19 mm	M16 24 mm	M16 24 mm	M20 30 mm
D	Hose clamp	M8 13 mm	M10 17 mm	M10 17 mm	M10 17 mm	M10 17 mm
E	Flange bracket bolts	M8 13 mm	M10 17 mm	M10 17 mm	M12 19 mm	M12 19 mm
F	Drive shaft bolts	M8 13 mm	M10 17 mm	M12 19 mm	M16 24 mm	M16 24 mm
G	Hub bolts	M10 17 mm	M10 17 mm	M12 19 mm	M16 24 mm	M16 24 mm
H	Support bolts	M10 17 mm	M10 17 mm	M12 19 mm	M16 24 mm	M16 24 mm
I	Gearbox bolts	M8 13 mm	M12 19 mm	M12 19 mm	M12 19 mm	M14 22 mm

## 10.2 Lubricant table gearbox

Below is an overview of some of the recommended lubricants for the planetary gearbox. In the majority of the cases a mineral oil ISO VG 150 or ISO VG 220 is recommended. In case of very low or ambient temperatures a mineral ISO VG 100 is advised. In case of high ambient temperatures or relatively wide range of ambient temperatures a synthetic oil is recommended. Also in case of very high loads, resulting in high operating temperatures a synthetic oil is to be preferred. Contact your Watson-Marlow Bredel representative for advice.

<b>Recommended lubricants for the Watson-Marlow Bredel planetary gearboxes*</b>				
	-20 °C to 5 °C -4 °F to 41 °F IV 95 min	5 °C to 30 °C 41 °F to 86 °F IV 95 min	5 °C to 50 °C 41 °F to 122 °F IV 95 min	-30 °C to 65 °C -22 °F to 149 °F IV 165 min
ISO 3448	VG 100	VG 150	VG 320	VG 150 - 220
AGIP	Blasia 100	Blasia 150	Blasia 320	Blasia SX 220
ARAL	Drgol BG 100	Drgol BG 150	Drgol BG 220	Drgol PAS 220
BP	Energol GR-XP 100	Energol GR-XP 150	Energol GR-XP 320	Energol EXP 220
CASTROL	Alphamax 100	Alphamax 150	Alphamax 320	Alphasyn PG150
ESSO	Spartan EP 100	Spartan EP 150	Spartan EP 320	Spartan SEP 220
Q8	Goya NT 100	Goya NT 150	Goya NT 320	El Greco 220
I.P.	Mellana 100	Mellana 150	Mellana 320	Telesia Oil 150
MOBIL	Mobilgear XMP 100	Mobilgear XMP 150	Mobilgear XMP 320	Mobilgear SHC XMP 220
SHELL	Omala oil 100	Omala oil 150	Omala oil 320	Omala HD 220
TOTAL FINA ELF	Carter EP 100	Carter EP 150	Carter EP 320	Carter SH 220
KLÜBER	Kluberoil GEM 1-150	Kluberoil GEM 1-150	Kluberoil GEM 1-320	Klubersynth EG 4-220
TEXACO	Meropa 100	Meropa 150	Meropa 320	Pinnacle EP

\* For a complete overview of the recommended lubricants contact your Watson-Marlow Bredel representative.

10.3 Parts list

10.3.1 Overview

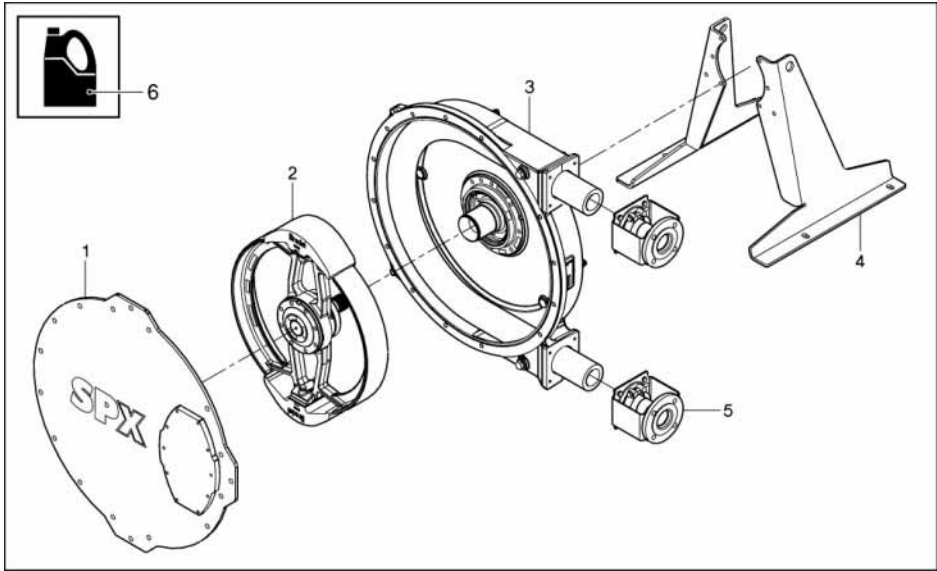

Pos.	Description
1	Cover assembly. Refer to § 10.3.2.
2	Rotor assembly. Refer to § 10.3.3.
3	Pump housing assembly. Refer to § 10.3.4.
4	Pump support assembly. Refer to § 10.3.5.
5	Flange assembly. Refer to § 10.3.6.
6	Lubricants. Refer to § 10.3.8.

**10.3.2 Cover assembly**

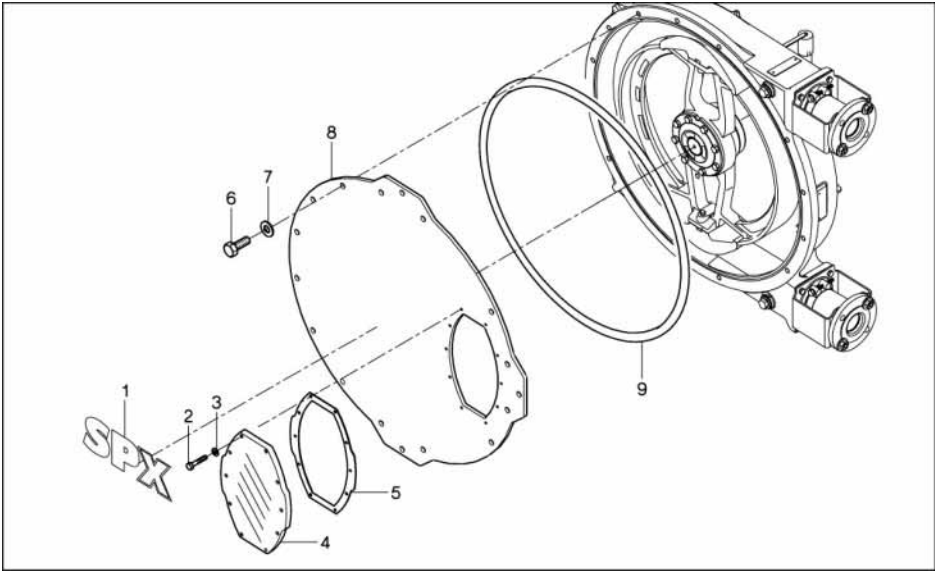

Pos.	Qty.	Description	Product codes for parts of pump type				
			SPX40	SPX50	SPX65	SPX80	SPX100
1	1	Sticker	240238	250238	265238	280238	280238
2	8	Bolt, hex. head	F111042	F111074	F101038	F101038	F101040
3	8	Washer, plain	F322009	F322012	F322012	F322012	F322012
4	1	Inspection window	240155	250155	265155	280155	200155
5	1	Gasket	240156	250156	265156	280156	200156
6	14	Bolt, hex. head	F111096	F111130	F111182	F111182	F111218
7	14	Washer, plain	F322013	F322015	F322017	F322017	F322019
8	1	Pump cover	240102	250102	265102	280102	200102
9	1	Quad ring	240123	250123	265123	280123	200123

10.3.3 Rotor assembly

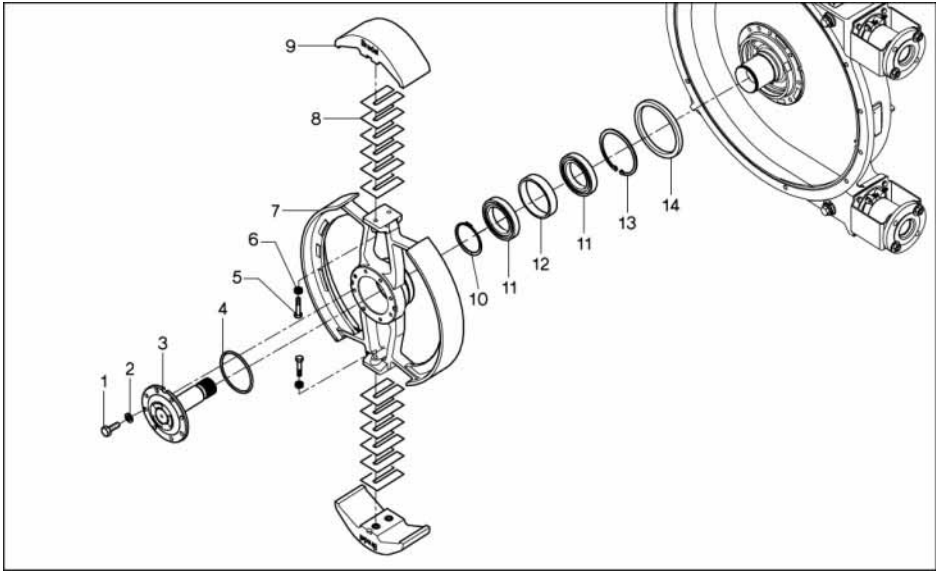

Pos.	Qty.	Description	Product codes for parts of pump type				
			SPX40	SPX50	SPX65	SPX80	SPX100
1	8*	Bolt, hex. head	F111073	F111098	F111132	F111184	F111184
2	8*	Washer, spring Lock	F336011	F336012	F336013	F336015	F336015
3	1	Drive shaft	240104	250104	265104	280104	200104
4	1	O-ring	S122431	S122541	122541	122611	S122611
5	2**	Bolt, hex. head	F101058	F101082	F101085	F101131	F101132
6	2**	NordLock® ring	F349005	F349007	F349007	F349009	F349009
7	1	Rotor	240103	250103	265103	280103	200103
8	12***	Shim	240107	250107	265107	280107	200107
9	2	Pressing shoe: aluminium	240110	250110	265110	280110	200110
	2	Epoxy, with stainless steel insert	240109A	250109A	265109A	280109A	200109A
10	1	Retaining ring	F343056	F343071	F343071	F343075	F343075
11	2	Bearing	B141460	B142060	B142060	B142460	B142460
12	1	Spacer outside	29110201	29150201	29151201	29180201	29181201
13	1	Retaining ring	F344077	F344087	F344087	F344093	F344093
14	1	Wear ring	29140202	29180202	29180202	29240202	29240202

- \* Pos. 1 and 2: SPX65, SPX80, SPX100: 12 pieces
- \*\* Pos. 5 and 6: SPX65, SPX80, SPX100: 4 pieces
- \*\*\* Pos. 8: SPX40: 12 pieces, SPX50 and SPX100: 14 pieces, SPX65 and SPX80: 20 pieces

### 10.3.4 Pump housing assembly

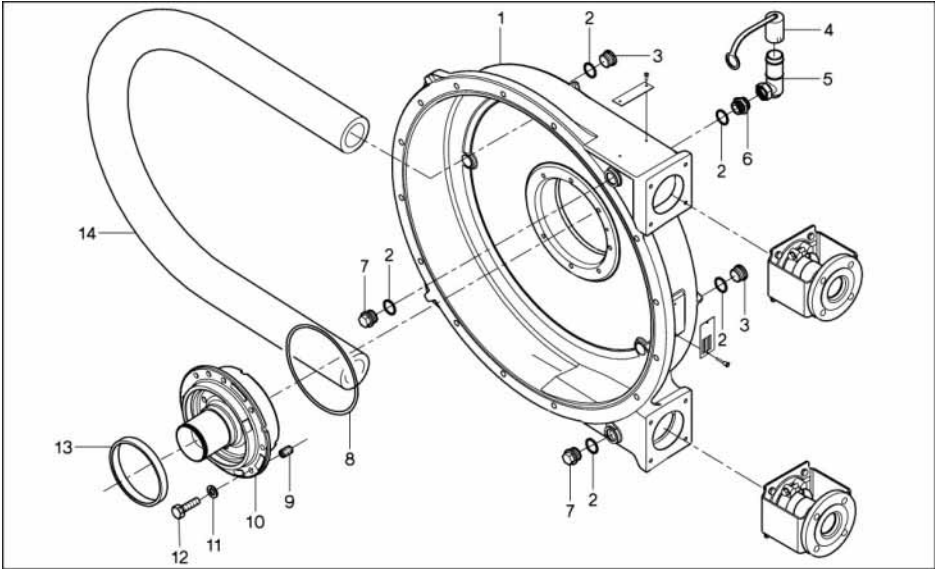

Pos.	Qty.	Description	Product codes for parts of pump type				
			SPX40	SPX50	SPX65	SPX80	SPX100
1	1	Pump housing	240101	250101	265101	280101	200101
2	4	Packing ring	29040257	29040257	29040257	29056244	29056244
3	2	Plug, int. hex. hd	F901006	F901006	F901006	F901008	F901008
4	1	Breather cap	29065223	29065223	29065223	29089223	29089223
5	1	Breather	29110146	29110146	29110146	29125146	29125146
6	1	Coupling, straight	F602006	F602006	F602006	F602008	F602008
7	2	Plug, ext. hex. hd.	F911006	F911006	F911006	F911008	F911008
8	1	O-ring	S122641	S122711	S122711	S122771	S122801
9	1	Dowel pin	F416082	F416082	F416082	F416121	F416121
10	1	Hub	240203	250203	265203	280203	200203
11	8	Washer, spring Lock	F336012	F336012	F336013	F336015	F336015
12	8	Bolt, hex. head	F115098	F115098	F115132	F115186	F115186
13	1	Seal	S212811	S213611	S213611	S214811	S214811

Pos.	Qty.	Description	Product codes for parts of pump type				
			SPX40	SPX50	SPX65	SPX80	SPX100
14	1	NR	040020	050020	065020	080020	100020
	1	NBR	040040	050040	065040	080040	100040
	1	EPDM	040075	050075	065075	080075	100075
	1	CSM	040070	050070	065070	080070	100070

**10.3.5 Support assembly**

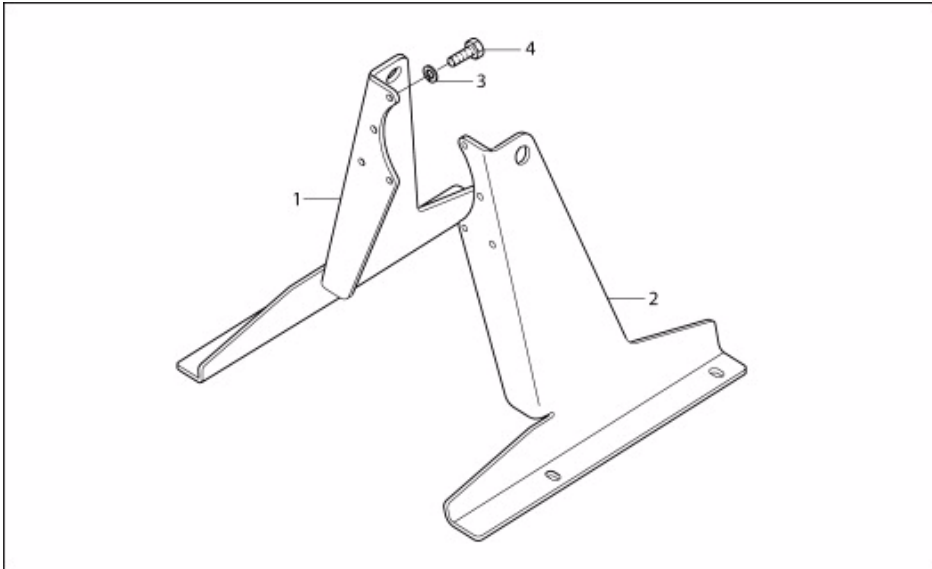

Pos.	Qty.	Description	Product codes for parts of pump type				
			SPX40	SPX50	SPX65	SPX80	SPX100
1	1	Support, right	240106B	250106B	265106B	280106B	200106B
2	1	Support, left	240106A	250106A	265106A	280106A	200106A
3	8	Washer, spring Lock	F336012	F336012	F336013	F336015	F336015
4	8	Bolt, hex. head	F111096	F111098	F111132	F111186	F111186

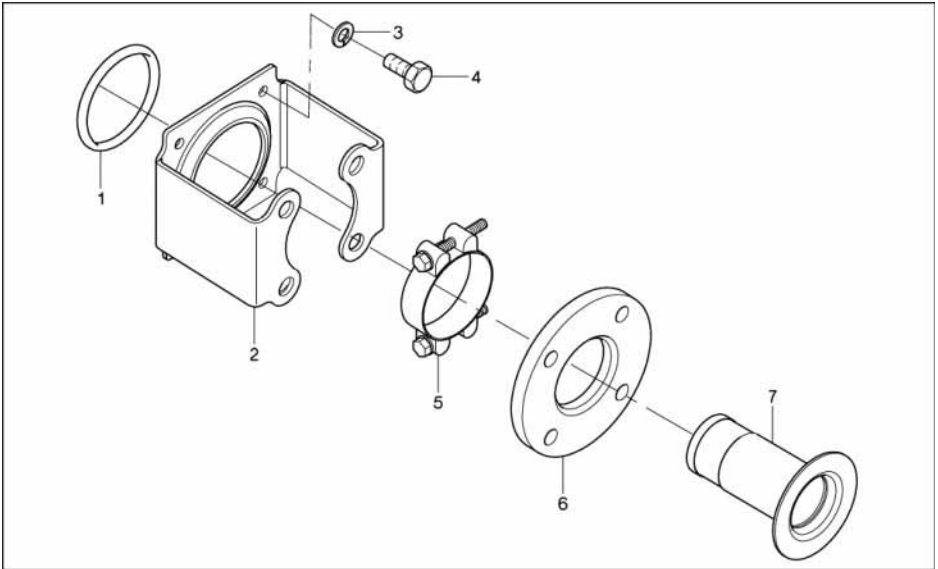
**10.3.6 Flange assembly**

Pos.	Qty.	Description	Product codes for parts of pump type				
			SPX40	SPX50	SPX65	SPX80	SPX100
1	2	O-ring	S112301	S112371	S112431	S112501	S115571
2	2	Flange bracket, DIN Steel	240197	250197	265197	280197	200197
	2	Flange bracket, DIN SS	240197E	250197E	265197E	280197E	200197E
	2	Flange bracket, ANSI Steel	240197A	250197	265197	280197A	200197
	2	Flange bracket, ANSI SS	240197F	250197E	265197E	280197F	200197E
3	8	Washer, spring lock	F336011	F336012	F336012	F336013	F336013
4	8	Bolt, hex. head	F111071	F111096	F111096	F111128	F111130
5	2	Hose clamp	C101021	C101045	C101048	C101051	C101054
6	2	Flange, DIN Steel	040198	050198	065198	080198	100198
6	2	Flange, DIN SS	240199	250199	265199	280199	200199
6	2	Flange, ANSI Steel	040198A	050198A	065198A	080198A	100198A
6	2	Flange, ANSI SS	240199A	250199A	265199A	280199A	200199A

Pos.	Qty.	Description	Product codes for parts of pump type				
			SPX40	SPX50	SPX65	SPX80	SPX100
7	1	Insert, AISI 316	040186	050186	265186	280186	200186
	1	Insert, PP	240189	250189	265189	280189	200189
	1	Insert, PVC	240187	250187	265187	280187	200187
	1	Insert, PVDF	240190	250190	265190	280190	200190

**10.3.7 Revolution counter assembly**

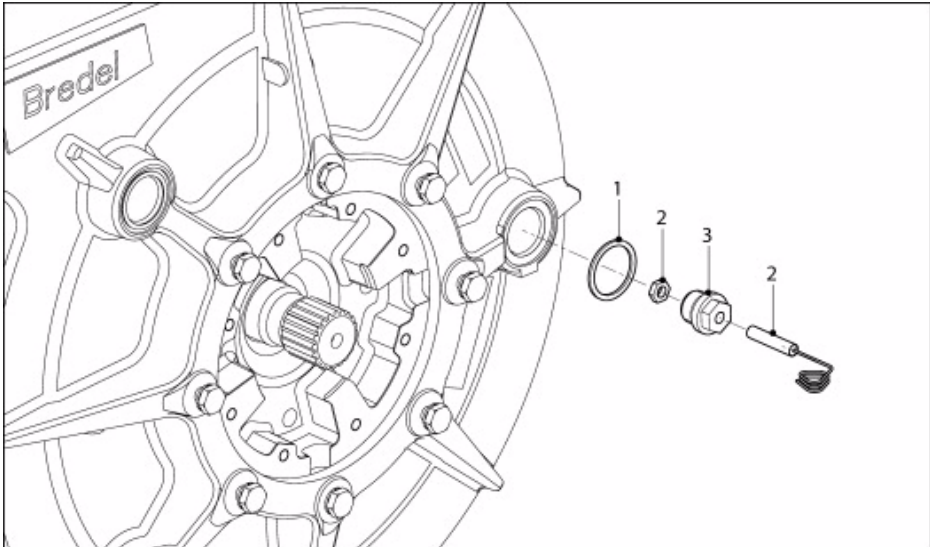

Pos.	Qty.	Description	Product codes for parts of pump type				
			SPX40	SPX50	SPX65	SPX80	SPX100
1	1	Gasket	29040257	29040257	29040257	29056244	29056244
2	1	Revolution counter	29040462	29040462	29040462	29040462	29040462
3	1	Adapter	29039460	29039460	29039460	29055460	29055460

**10.3.8 Lubricants**

Pos.	Qty.	Description	Product codes for parts of pump type				
			SPX40	SPX50	SPX65	SPX80	SPX100
1	1	5 l (1.3 gal) can Watson-Marlow Bredel Genuine Hose Lubricant	903143	-	-	-	-
	1	10 l (2.6 gal) can Watson-Marlow Bredel Genuine Hose Lubricant	-	904143	-	-	-
	1	20 l (5.3 gal) can Watson-Marlow Bredel Genuine Hose Lubricant	-	-	905143	-	-
	2		-	-	-	905143	-
	3		-	-	-	-	905143



**11 SAFETY FORM**

**Product Use and Decontamination Declaration**

In compliance with the **Health & Safety Regulations**, the user is required to declare those substances that have been in contact with the item(s) you are returning to Watson-Marlow Bredel B.V. or any of its subsidiaries or distributors. Failure to do so will cause delays in servicing the item or in issuing a response. Therefore, **please complete this form** to make sure we have the information before receipt of the item(s) being returned. A completed copy must be attached to **the outside of the packaging** containing the item(s). You, the user, are responsible for cleaning and decontaminating the item(s) before returning them.

Please complete a separate Decontamination Certificate for each item returned. **RGA no** .....

1 Company .....

Address .....

Postal code.....

Telephone ..... Fax number .....

2 Product ..... 3.4 Cleaning fluid to be used if residue of chemical is found during servicing;

2.1 Serial Number .....

2.2 Has the Product been used?

YES  NO

If yes, please complete all the following paragraphs.

If no, please complete paragraph 5 only

a) .....

b) .....

c) .....

d) .....

3 Details of substances pumped

3.1 Chemical Names

a) .....

b) .....

c) .....

d) .....

4 I hereby confirm that the only substances(s) that the equipment specified has pumped or come into contact with are those named, that the information given is correct, and the carrier has been informed if the consignment is of a hazardous nature.

3.2 Precautions to be taken in handling these substances:

a) .....

b) .....

c) .....

d) .....

5 Signed .....

Name .....

Position .....

Date .....

3.3 Action to be taken in the event of human contact:

a) .....

b) .....

c) .....

d) .....

**Note:**

**To assist us in our servicing please describe any fault condition you have witnessed.**

.....

.....

.....

29210302 TS 02-013-D

Watson-Marlow Pumps Group  
37 Upton Technology Park  
Wilmington, MA 01887  
USA

Telephone: 800 - 282 - 8823  
978 - 658 - 6168  
Fax: 978 - 658 - 0041

Internet: [www.wmpg.com](http://www.wmpg.com)  
E-mail: [support@wmpg.us](mailto:support@wmpg.us)



© 2010 Watson-Marlow Bredel B.V.