

120S/D1 and 120U/D1 cased pumps fitted with 400D1 pumphead

100 series

Watson-Marlow Pumps Group

COMMON FEATURES AND BENEFITS

- Flow rates 0.001 to 120ml/min at 2 bar (30psi)
- Compact footprint requiring minimal benchtop space
- Superior speed control up to 20,000:1, $\pm 1\%$ set speed accuracy
- 400D1 single-channel pumphead with three rollers, accepts continuous tubing only
- IP31 ingress protection for wipedown environments
- Maintenance-free brushless DC motor

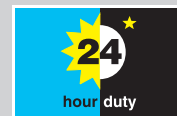

Watson-Marlow...Innovation in Full Flow

TECHNICAL DATA

Functionality	120S	120U
Manual control		
1 to 200rpm (200:1)	•	
0.1 to 200rpm (2000:1)		•
Numerical speed display	•	•
Reversible direction	•	•
Max (prime)	•	•
Auto start	•	•
Remote control		
Run/stop, direction change, auto/man toggle, alarm		•
Analogue control		
0.01 to 200rpm (20,000:1)		•
Analogue speed input; 4-20mA, 0-10V		•
Tacho speed output; 0-5V		•
Security		
Keypad lock to protect set-up	•	•

PERFORMANCE

Tube bore and flow rates 102S/D1 and 120U/D1 (ml/min)							
	Speed rpm	0.5mm	0.8mm	1.6mm	2.4mm	3.2mm	4.0mm
120S/D1	1 - 200rpm	0.01 - 2.2	0.03 - 5.8	0.11 - 23	0.24 - 49	0.41 - 81	0.59 - 120
120U/D1	0.1 - 200rpm	0.001 - 2.2	0.003 - 5.8	0.011 - 23	0.024 - 49	0.041 - 81	0.059 - 120

TECHNICAL DRAWINGS

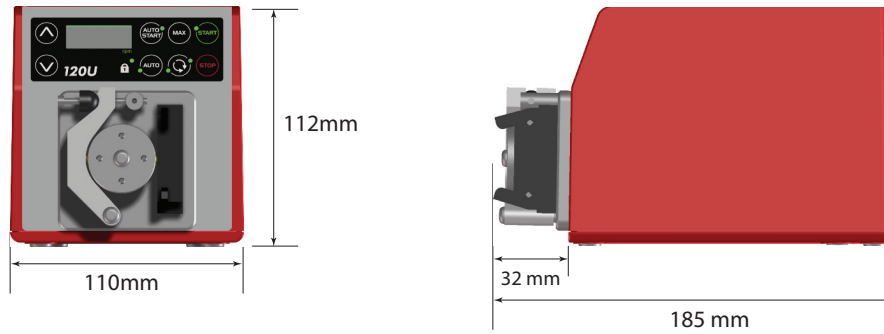

TECHNICAL SPECIFICATION

120S, 120U	
Ingress rating	IP31 / NEMA 2
Enclosure	Wipedown
Suitability	Dry light-industrial environments
Humidity	Non-condensing 80% up to 31C, 88F, decreasing linearly to 50% at 40C, 104F
Temperature	5C to 40C (40F to 104F)
Pump weight	1.65kg (3lbs 9oz)
Control ratio	120S: 200:1, 120U: Manual 2000:1, Auto 20,000:1
Torque rating	0.4Nm continuous duty
Noise	< 60dB(A) at 1m
Standard	CE, cETLus
Power supply	24VDC from mains transformer supplied (mains supply range 90~264VAC 47~63Hz)

MATERIALS OF CONSTRUCTION

Component	Material
Keypad	Polyester
Drive casework	ABS plastic
Drive shaft	Stainless Steel
Pumphead track	Aluminium (anodised)
Rotor	Aluminium (anodised)
Rollers	Acetal
Spindles guide pins	Stainless steel

ORDER INFORMATION

Pump and pumphead product codes			
Description	Partcode	Description	Partcode
120S/D1 manual speed pump	010.6131.010	400D1 pumphead	043.001D.D1C
120U/D1 manual and auto pump	010.6141.010		

Tubing 1.6mm wall thickness for 400D1						
	0.5mm	0.8mm	1.6mm	2.4mm	3.2mm	4.0mm
Bioprene	903.0005.016	903.0008.016	903.0016.016	903.0024.016	903.0032.016	
Pumpsil (Silicone)	913.A005.016	913.A008.016	913.A016.016	913.A024.016	913.A032.016	
STA-PURE PCS			960.0016.016		960.0032.016	
Marprene	902.0005.016	902.0008.016	902.0016.016	902.0024.016	902.0032.016	902.0040.016
STA-PURE PFL			965.0016.016		965.0032.016	
PVC			950.0016.016		950.0032.016	
Neoprene		920.0008.016	920.0016.016		920.0032.016	

All flow rates shown were obtained pumping water at 20C (68F) with zero suction and delivery heads. Watson-Marlow, Pumpsil, Bioprene and Marprene are trademarks of Watson-Marlow Limited. Disclaimer: The information contained in this document is believed to be correct but Watson-Marlow Limited accepts no liability for any errors it contains, and reserves the right to alter specifications without notice. © STA-PURE PCS and © STA-PURE PFL are registered trademarks of W.L. Gore & Associates Inc.

**WATSON
MARLOW**
Watson-Marlow Pumps Group

Watson-Marlow Pumps Group
Falmouth, Cornwall England TR11 4RU
Tel: +44 (0)1326 370370 Fax: +44 (0)1326 376009
www.wmpg.com info@wmpg.co.uk
Watson-Marlow...Innovation in Full Flow